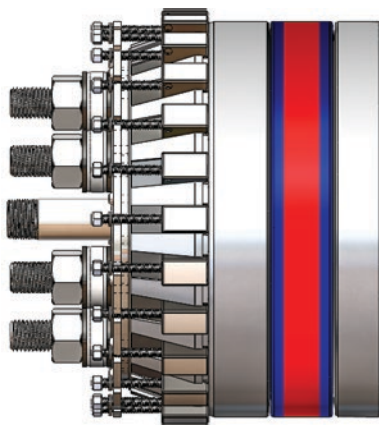




# GRIPSAFE®

## INSTALLATION MANUAL



---

### Large Outboard Retraction Blocking (ORB) Plug

---

Manufactured Exclusively by USA Industries, Inc.  
an ISO 9001:2015 Certified Company

Patents & Trademarks

- US PATENTS: 9,927,058 | 9,810,364 | D894,349 | 10,746,339
- CANADIAN PATENT: 3,004,787
- CANADIAN INDUSTRIAL DESIGN: CA 186293
- EUROPEAN PATENT: 3,377,797 B1
- EUROPEAN PATENT [Germany]: 602016051864.3
- EUROPEAN UNION DESIGN REGISTRATION: 00628264-001
- INTERNATIONAL TRADEMARK REGISTRATION: 1550298
- Other US and Foreign Patents Pending

[www.USAIndustries.com](http://www.USAIndustries.com)

(713) 941-3797 • (800) 456-8721

## Contents

---

1. Introduction	2
2. Safety	3
3. Parts	4
4. Specifications	7
5. Preparing the GripSafe ORB Plug for Installation	12
6. Installing the GripSafe ORB Plug	13
7. GripSafe ORB Plug Removal	17
8. GripSafe Lifting Device	19

## 1. Introduction

---

USA Industries, Inc. thanks you for choosing GripSafe pipe plugging technology. This manual covers the proper use of this technology to ensure safe operating conditions.



**WARNING:** Do not use GripSafe equipment before fully reading and comprehending this manual. Failure to follow this manual in full may result in injury to personnel and damage to equipment.

All necessary sockets, wrenches and lifting device to install this equipment are available for rental or purchase from USA Industries, Inc. See **Section 4, Table 2** for sockets and **Section 8, Table 4** for lifting device.

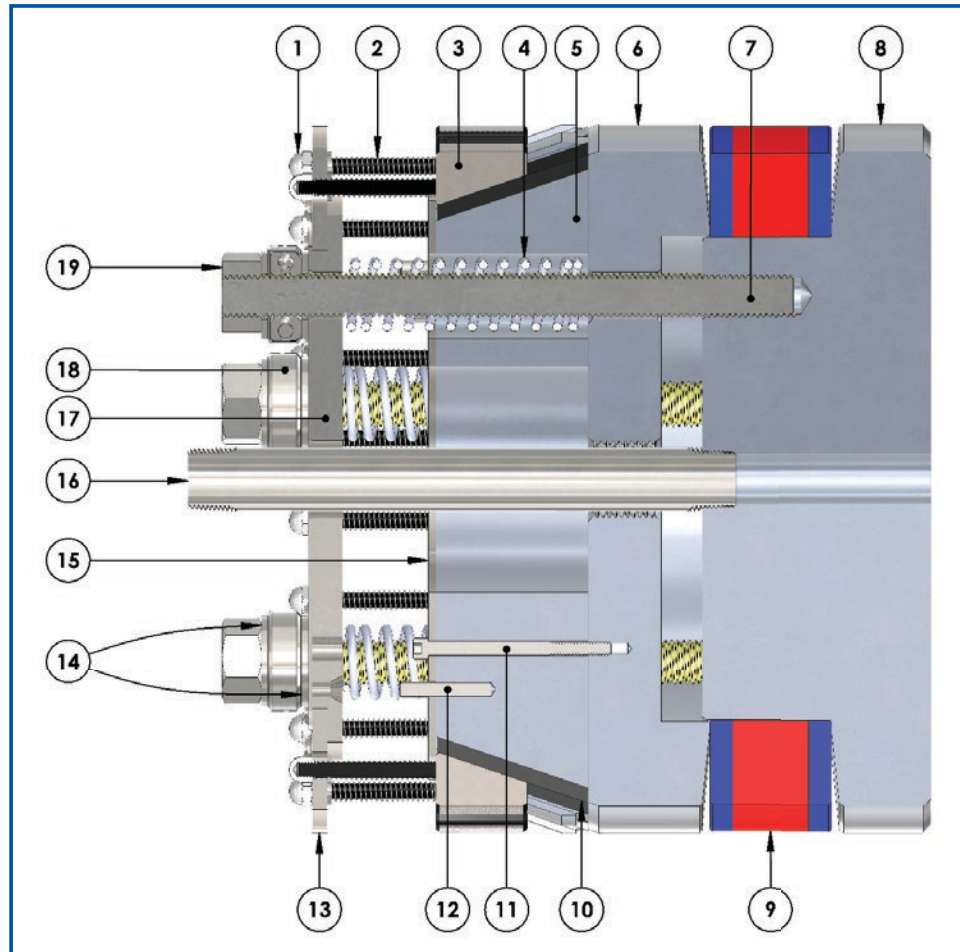
The information in this manual is for the use of a GripSafe plug in metallic piping. If the intended use of this plug is for any piping other than metallic piping, please contact USA Industries, Inc.'s Customer Service Department for technical support.

## 2. Safety

---

- ⚠ Failure to follow proper safety requirements may result in the GripSafe plug failing, which could lead to personnel injury, material loss, and/or damage to equipment.
- ⚠ Wear proper Personal Protective Equipment (PPE) when performing any task with the GripSafe plug as defined by site safety rules. Always follow site procedure for safely lifting and operating equipment.
- ⚠ Never install the GripSafe plug in a position where the *Gripping Wedge* would be located over weld droop or ridge.
- ⚠ Never install the *Seals* or *Gripping Wedge* over a section of pipe that is missing its interior wall; i.e. weldolet, tee, etc.
- ⚠ Use care in the handling of the *Wedge Studs*. Never beat, hammer, or pry on the *Wedge Studs*, and never remove the nut located on the *Wedge Studs*.
- ⚠ Pressure testing can be a hazardous operation and safety precautions are important. Never stand or pass in front of a test plug during installation, testing, and removal.
- ⚠ Do not make adjustments to the plug, safety equipment, or vessel while the plug is under pressure.
- ⚠ Do not exceed rated pressure stamped on the plug. Plugs are rated for holding pressure in one direction; never apply pressure on the non-rated side of the plug.
- ⚠ Maximum plug back pressure rating references the plugs ultimate holding capacity. Never exceed the pressure capacity of the weakest component in a pressurized system. Study your system's components prior to beginning a pressure test to ascertain and confirm that the maximum test pressure your system is subjected to with the use of the GripSafe plug adheres to the limits given by *Table 3*, and is in accordance with all applicable industry and site-specific standards.
- ⚠ We recommend using water as the test medium. Before pressurizing the system, vent all gases from the vessel.
- ⚠ If performing pneumatic testing, all attempts to limit potential damage to personnel or equipment is critical. USA Industries, Inc. recommends Nitrogen as the medium for pneumatic testing as it does not support combustion. Follow provisions outlined in ASME PCC-2 Repair of Pressure Equipment and Piping when testing pneumatically.
- ⚠ For Maximum Allowable Pressures refer to *Table 3*; DO NOT EXCEED the pressure ratings identified in this the table when pressurizing the system. Carefully observe the outside of the pipe at the location where the *Wedge Grippers* make contact when performing a hydro test. If you observe any deformation or swelling of the pipe, stop immediately and slowly release the pressure from the system. **Contact USA Industries, Inc. for further assistance.**
- ⚠ If you hear a popping or clicking sound at any time during a hydro test, stop immediately and slowly release the pressure from the system. Popping or clicking sounds during hydro testing may be a sign of the *Wedge Gripper* slipping, cracking, or one of the plug components failing. Remove the plug from the pipe or fitting and inspect for damage. **Contact USA Industries, Inc. for further assistance.**
- ⚠ Make sure the plug is clean of debris and contaminants. Each *Wedge Gripper* should freely slide up and down in its slot with a full range-of-motion, and incur no resistance. If you experience impeded movement due to debris, dirt or contaminants, the plug may not grip the pipe's ID securely, which can cause plug ejection under pressure, potentially leading to injury, death, material loss, and/or damage.
- ⚠ **For any questions or concerns, contact USA Industries, Inc. for technical assistance.**

**3. Parts** (*This manual references the part numbers identified below throughout the document*)



**Figure 1: GripSafe ORB Diagram**



Table 1: GripSafe Bill of Materials

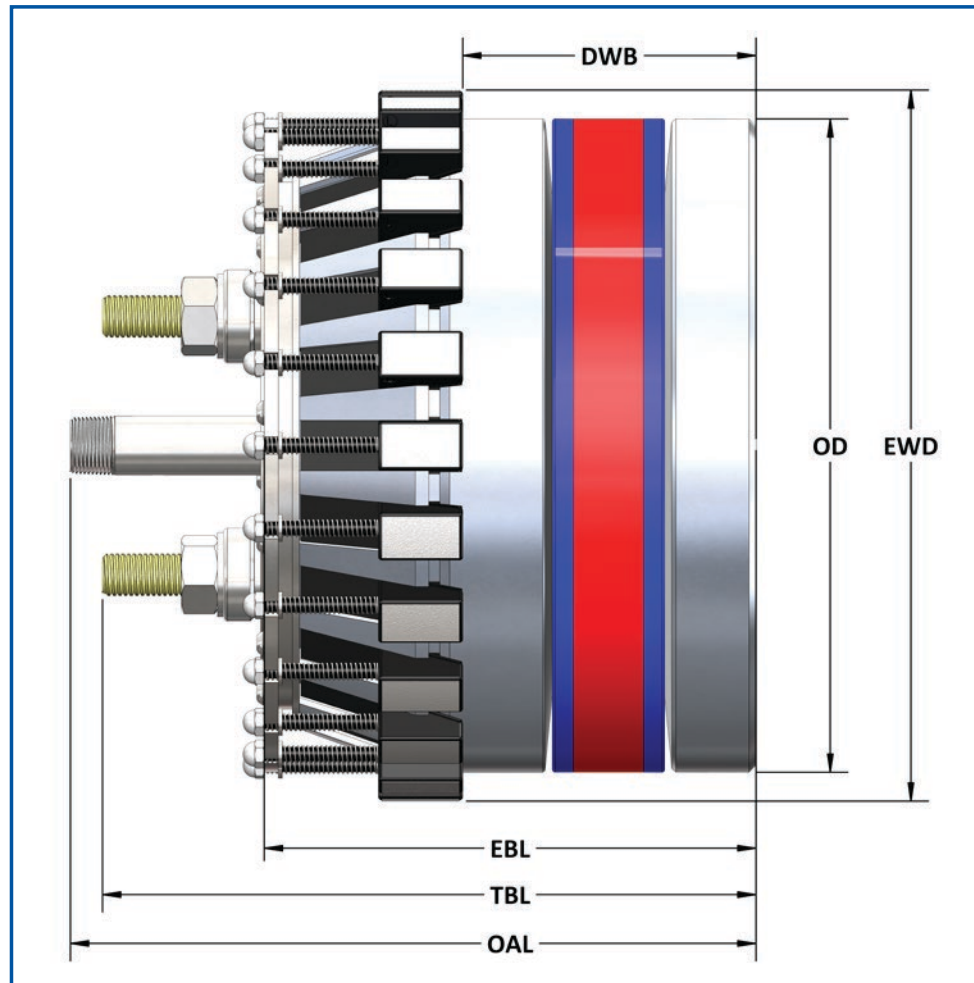
Nominal Pipe Size (in)	Schedule	①	②	③	④	⑤	⑥	⑦	⑧	⑨	⑩	⑪	⑫	⑬	⑭	⑮	⑯	⑰	⑱	⑲
		Wedge Gripper Nut	Wedge Gripper Stem With Spring	Wedge Gripper	Retraction Compression Spring	Wedge Cone	Top Compression Plate	All-Thread Shaft	Bottom Compression Plate	Seal	Back Plate	Wedge Cone Retaining Screw	Alignment Dowel Pin	Spring Plate Halo	Compression Washers	Retainer Plate	Back Pressure Vent Port	Spring Plate Hub	Thrust Bearing	Compression Hex Nut
6	10S-80S	9	9	9	1	1	1	4	1	1	9	2	2	0	8	1	1	1	4	4
	120	8	8	8	1	1	1	4	1	1	8	2	2	0	8	1	1	1	4	4
	160	7	7	7	1	1	1	4	1	1	7	2	2	0	8	1	1	1	4	4
	XXH	6	6	6	1	1	1	4	1	1	6	2	2	0	8	1	1	1	4	4
8	10S-80S	15	15	15	1	1	1	4	1	1	15	2	2	0	8	1	1	1	4	4
	100	14	14	14	1	1	1	4	1	1	14	2	2	0	8	1	1	1	4	4
	120-140	13	13	13	1	1	1	4	1	1	13	2	2	0	8	1	1	1	4	4
	160-XXH	12	12	12	1	1	1	4	1	1	12	2	2	0	8	1	1	1	4	4
10	10S-100	20	20	20	4	1	1	4	1	1	20	2	2	1	8	1	1	1	4	4
	120	19	19	19	1	1	1	4	1	1	19	2	2	0	8	1	1	1	4	4
	140,XXH	18	18	18	1	1	1	4	1	1	18	2	2	0	8	1	1	1	4	4
	160	17	17	17	1	1	1	4	1	1	17	2	2	0	8	1	1	1	4	4
12	10S-80S	24	24	24	4	1	1	4	1	1	24	2	2	1	8	1	1	1	4	4
	60-80	25	25	25	4	1	1	4	1	1	25	2	2	1	8	1	1	1	4	4
	100	24	24	24	4	1	1	4	1	1	24	2	2	1	8	1	1	1	4	4
	120,XXH	23	23	23	4	1	1	4	1	1	23	2	2	1	8	1	1	1	4	4
	140	22	22	22	4	1	1	4	1	1	22	2	2	1	8	1	1	1	4	4
	160	21	21	21	4	1	1	4	1	1	21	2	2	1	8	1	1	1	4	4
14	10S-80S	24	24	24	6	1	1	6	1	1	24	4	2	1	12	1	1	1	6	6
	60-100	27	27	27	6	1	1	6	1	1	27	4	2	1	12	1	1	1	6	6
	120	26	26	26	6	1	1	6	1	1	26	4	2	1	12	1	1	1	6	6
	140	25	25	25	6	1	1	6	1	1	25	4	2	1	12	1	1	1	6	6
	160	24	24	24	6	1	1	6	1	1	24	4	2	1	12	1	1	1	6	6
16	10S-80	32	32	32	6	1	1	6	1	1	32	4	2	1	12	1	1	1	6	6
	100	31	31	31	6	1	1	6	1	1	31	4	2	1	12	1	1	1	6	6
	120	30	30	30	6	1	1	6	1	1	30	4	2	1	12	1	1	1	6	6
	140	29	29	29	6	1	1	6	1	1	29	4	2	1	12	1	1	1	6	6
	160	28	28	28	6	1	1	6	1	1	28	4	2	1	12	1	1	1	6	6
18	10S-80S	36	36	36	6	1	1	6	1	1	36	4	2	1	12	1	1	1	6	6
	40-60	38	38	38	6	1	1	6	1	1	38	4	2	1	12	1	1	1	6	6
	80	37	37	37	6	1	1	6	1	1	37	4	2	1	12	1	1	1	6	6
	100	36	36	36	6	1	1	6	1	1	36	4	2	1	12	1	1	1	6	6
	120	35	35	35	6	1	1	6	1	1	35	4	2	1	12	1	1	1	6	6
	140	34	34	34	6	1	1	6	1	1	34	4	2	1	12	1	1	1	6	6
160	33	33	33	6	1	1	6	1	1	33	4	2	1	12	1	1	1	6	6	



Table 1: GripSafe Bill of Materials Continued

Nominal Pipe Size (in)	Schedule	①	②	③	④	⑤	⑥	⑦	⑧	⑨	⑩	⑪	⑫	⑬	⑭	⑮	⑯	⑰	⑱	⑲
		Wedge Gripper Nut	Wedge Gripper Stem With Spring	Wedge Gripper	Retraction Compression Spring	Wedge Cone	Top Compression Plate	All-Thread Shaft	Bottom Compression Plate	Seal	Back Plate	Wedge Cone Retaining Screw	Alignment Dowel Pin	Spring Plate Halo	Compression Washers	Retainer Plate	Back Pressure Vent Port NPT	Spring Plate Hub	Thrust Bearing	Compression Hex Nut
20	10S-80S	40	40	40	8	1	1	8	1	1	40	4	2	1	16	1	1	1	8	8
	40	44	44	44	8	1	1	8	1	1	44	4	2	1	16	1	1	1	8	8
	60	43	43	43	8	1	1	8	1	1	43	4	2	1	16	1	1	1	8	8
	80	42	42	42	8	1	1	8	1	1	42	4	2	1	16	1	1	1	8	8
	100	41	41	41	8	1	1	8	1	1	41	4	2	1	16	1	1	1	8	8
	120	40	40	40	8	1	1	8	1	1	40	4	2	1	16	1	1	1	8	8
	140	38	38	38	8	1	1	8	1	1	38	4	2	1	16	1	1	1	8	8
160	37	37	37	8	1	1	8	1	1	37	4	2	1	16	1	1	1	8	8	
24	10S-80S	48	48	48	8	1	1	8	1	1	48	4	2	1	16	1	1	1	8	8
	30	55	55	55	8	1	1	8	1	1	55	4	2	1	16	1	1	1	8	8
	40	54	54	54	8	1	1	8	1	1	54	4	2	1	16	1	1	1	8	8
	60	53	53	53	8	1	1	8	1	1	53	4	2	1	16	1	1	1	8	8
	80	52	52	52	8	1	1	8	1	1	52	4	2	1	16	1	1	1	8	8
	100	50	50	50	8	1	1	8	1	1	50	4	2	1	16	1	1	1	8	8
	120	48	48	48	8	1	1	8	1	1	48	4	2	1	16	1	1	1	8	8
140	47	47	47	8	1	1	8	1	1	47	4	2	1	16	1	1	1	8	8	
160	46	46	46	8	1	1	8	1	1	46	4	2	1	16	1	1	1	8	8	

## 4. Specifications



**Figure 2:** GripSafe ORB Dimensions Diagram



**Table 2: GripSafe ORB Specifications**

Nominal Pipe Size (in)	Schedule	Part Number	Tool Diameter (in)	Rec. ID Range* (in)	Nominal Pipe ID Clearance (in)	Approx. Tool Weight (lbs)	Tool Length (in)	Torque Range (ft-lbs)		Comp. Hex Nut Socket Size (in)	Back Pressure Vent Thread	Max Plug Back Pressure Rating (PSI)
								Norm	Max.			
4	10,10S	GS-I-S-0400-010	4.04	4.102 - 4.540	0.220	21	13.38	120	250	1-5/16"	1/4" FNPT	4875
	40,STD,40S	GS-I-S-0400-040	3.81	3.868 - 4.306	0.220	19	13.38	120	250	1-5/16"	1/4" FNPT	5450
	80,XS,80S	GS-I-S-0400-080	3.61	3.668 - 4.106	0.220	17	13.38	120	250	1-5/16"	1/4" FNPT	6050
6	10,10S	GS-I-S-0600-010	5.98	6.044 - 6.422	0.375	26	12.40	85	130	1-1/16"	1/4" MNPT	3300
	40,STD,40S	GS-I-S-0600-040	5.69	5.752 - 6.129	0.375	24	12.40	75	110	1-1/16"	1/4" MNPT	3600
	80,XS,80S	GS-I-S-0600-080	5.39	5.448 - 5.823	0.375	21	12.40	60	95	1-1/16"	1/4" MNPT	4000
	120	GS-I-S-0600-120	5.13	5.188 - 5.562	0.375	19	12.40	55	80	1-1/16"	1/4" MNPT	3900
	160	GS-I-S-0600-160	4.81	4.874 - 5.246	0.375	17	12.40	40	60	3/4"	1/4" MNPT	3850
	XXH	GS-I-S-0600-XXH	4.52	4.584 - 4.955	0.375	15	12.40	35	55	3/4"	1/4" MNPT	3700
8	10,10S	GS-I-S-0800-010	7.95	8.016 - 8.404	0.375	51	12.25	120	150	1-1/4"	1/2" MNPT	3200
	20	GS-I-S-0800-020	7.75	7.812 - 8.199	0.375	49	12.25	120	150	1-1/4"	1/2" MNPT	3350
	30	GS-I-S-0800-030	7.70	7.758 - 8.145	0.375	48	12.25	120	150	1-1/4"	1/2" MNPT	3400
	40,STD,40S	GS-I-S-0800-040	7.61	7.668 - 8.054	0.375	46	12.25	120	150	1-1/4"	1/2" MNPT	3475
	60	GS-I-S-0800-060	7.44	7.500 - 7.885	0.375	45	12.25	120	150	1-1/4"	1/2" MNPT	3625
	80,XS,80S	GS-I-S-0800-080	7.25	7.312 - 7.696	0.375	43	12.25	120	150	1-1/4"	1/2" MNPT	3800
	100	GS-I-S-0800-100	7.06	7.124 - 7.507	0.375	40	12.25	100	150	1-1/4"	1/2" MNPT	3725
	120	GS-I-S-0800-120	6.81	6.874 - 7.256	0.375	38	12.25	100	150	1-1/4"	1/2" MNPT	3725
	140	GS-I-S-0800-140	6.63	6.688 - 7.069	0.375	36	12.25	90	150	1-1/16"	1/4" MNPT	3925
	160	GS-I-S-0800-160	6.44	6.500 - 6.880	0.375	34	12.25	90	150	1-1/16"	1/4" MNPT	3825
	XXH	GS-I-S-0800-XXH	6.50	6.562 - 6.943	0.375	34	12.25	90	150	1-1/16"	1/4" MNPT	3750
10	10,10S	GS-I-S-1000-010	10.05	10.107 - 10.505	0.375	74	12.25	120	150	1-1/4"	3/4" MNPT	2725
	20	GS-I-S-1000-020	9.88	9.937 - 10.335	0.375	71	12.25	120	150	1-1/4"	3/4" MNPT	2800
	30	GS-I-S-1000-030	9.76	9.823 - 10.220	0.375	70	12.25	120	150	1-1/4"	3/4" MNPT	2875
	40,STD,40S	GS-I-S-1000-040	9.65	9.707 - 10.103	0.375	68	12.25	120	150	1-1/4"	3/4" MNPT	2950
	60,XS,80S	GS-I-S-1000-08S	9.38	9.437 - 9.832	0.375	65	12.25	120	150	1-1/4"	3/4" MNPT	3100
	80	GS-I-S-1000-080	9.19	9.249 - 9.643	0.375	62	12.25	120	150	1-1/4"	3/4" MNPT	3225
	100	GS-I-S-1000-100	8.94	8.999 - 9.392	0.375	58	12.25	120	150	1-1/4"	3/4" MNPT	3400
	120	GS-I-S-1000-120	8.69	8.749 - 9.141	0.375	56	12.25	120	150	1-1/4"	3/4" MNPT	3425
	140,XXH	GS-I-S-1000-140	8.38	8.437 - 8.827	0.375	54	12.25	120	150	1-1/4"	1/2" MNPT	3475
160	GS-I-S-1000-160	8.13	8.187 - 8.576	0.375	53	12.25	120	150	1-1/4"	1/2" MNPT	3475	
12	10,10S	GS-I-S-1200-010	12.02	12.077 - 12.485	0.375	100	12.25	120	150	1-1/4"	3/4" MNPT	2300
	20	GS-I-S-1200-020	11.88	11.937 - 12.345	0.375	98	12.25	120	150	1-1/4"	3/4" MNPT	2375
	30	GS-I-S-1200-030	11.72	11.777 - 12.184	0.375	96	12.25	120	150	1-1/4"	3/4" MNPT	2425
	STD,40S	GS-I-S-1200-04S	11.63	11.687 - 12.093	0.375	93	12.25	120	150	1-1/4"	3/4" MNPT	2475
	40	GS-I-S-1200-040	11.56	11.625 - 12.031	0.375	92	12.25	120	150	1-1/4"	3/4" MNPT	2500
	XS,80S	GS-I-S-1200-08S	11.38	11.437 - 11.842	0.375	91	12.25	120	150	1-1/4"	3/4" MNPT	2575
	60	GS-I-S-1200-060	11.25	11.313 - 11.717	0.375	88	12.25	120	150	1-1/4"	3/4" MNPT	2725
	80	GS-I-S-1200-080	11.00	11.061 - 11.464	0.375	84	12.25	120	150	1-1/4"	3/4" MNPT	2850
	100	GS-I-S-1200-100	10.69	10.749 - 11.151	0.375	80	12.25	120	150	1-1/4"	3/4" MNPT	2900
	120,XXH	GS-I-S-1200-120	10.38	10.437 - 10.837	0.375	78	12.25	120	150	1-1/4"	3/4" MNPT	2950
	140	GS-I-S-1200-140	10.13	10.187 - 10.586	0.375	76	12.25	120	150	1-1/4"	3/4" MNPT	2950
160	GS-I-S-1200-160	9.75	9.813 - 10.210	0.375	72	12.25	120	150	1-1/4"	3/4" MNPT	3025	
14	10S	GS-I-S-1400-01S	13.25	13.311 - 13.725	0.375	129	12.12	120	300	1-5/8"	1" MNPT	1925
	10	GS-I-S-1400-010	13.13	13.187 - 13.601	0.375	127	12.12	120	300	1-5/8"	1" MNPT	1950
	20	GS-I-S-1400-020	13.00	13.063 - 13.476	0.375	125	12.12	120	300	1-5/8"	1" MNPT	1975
	30,STD,40S	GS-I-S-1400-04S	12.88	12.937 - 13.333	0.375	121	12.12	120	300	1-5/8"	1" MNPT	2025
	40	GS-I-S-1400-040	12.75	12.811 - 13.223	0.375	120	12.12	120	250	1-5/8"	1" MNPT	2050
	XS,80S	GS-I-S-1400-08S	12.63	12.687 - 13.098	0.375	119	12.12	120	250	1-5/8"	1" MNPT	2100
	60	GS-I-S-1400-060	12.44	12.499 - 12.909	0.375	114	12.12	120	250	1-5/8"	1" MNPT	2425
	80	GS-I-S-1400-080	12.13	12.187 - 12.596	0.375	108	12.12	120	250	1-5/8"	1" MNPT	2550
	100	GS-I-S-1400-100	11.75	11.811 - 12.218	0.375	102	12.12	120	250	1-5/8"	1" MNPT	2725
	120	GS-I-S-1400-120	11.44	11.499 - 11.904	0.375	96	12.12	120	250	1-5/8"	1" MNPT	2750
	140	GS-I-S-1400-140	11.13	11.187 - 11.591	0.375	91	12.12	120	250	1-5/8"	1" MNPT	2800
160	GS-I-S-1400-160	10.81	10.875 - 11.277	0.375	86	12.12	120	250	1-5/8"	1" MNPT	2825	

• Larger sizes and custom configurations available upon request. Smaller sizes release date pending.

\* NPS 6-24 TOOL OD MUST BE WITHIN 1/8" CONCENTRICITY TO THE PIPE ID.

• NEVER EXCEED THE MAXIMUM RATED PRESSURE OF THE LOWEST RATED COMPONENT IN THE SYSTEM.

• DATA IS SUBJECT TO CHANGE. Consult manufacturer to verify that this document is the latest release.



**Table 2: GripSafe ORB Specifications Continued**

Nominal Pipe Size (in)	Schedule	Part Number	Tool Diameter (in)	Rec. ID Range* (in)	Nominal Pipe ID Clearance (in)	Approx. Tool Weight (lbs)	Tool Length (in)	Torque Range (ft-lbs)		Comp. Hex Nut Socket Size (in)	Back Pressure Vent Thread	Max Plug Back Pressure Rating (PSI)
								Norm	Max.			
16	10S	GS-I-S-1600-01S	15.25	15.311 - 15.735	0.375	173	12.12	120	300	1-5/8"	1" MNPT	1950
	10	GS-I-S-1600-010	15.13	15.187 - 15.611	0.375	170	12.12	120	300	1-5/8"	1" MNPT	1975
	20	GS-I-S-1600-020	15.00	15.063 - 15.486	0.375	167	12.12	120	300	1-5/8"	1" MNPT	2000
	30,STD,40S	GS-I-S-1600-04S	14.88	14.937 - 15.360	0.375	164	12.12	120	300	1-5/8"	1" MNPT	2025
	40,XS,80S	GS-I-S-1600-08S	14.63	14.687 - 15.108	0.375	159	12.12	120	300	1-5/8"	1" MNPT	2100
	60	GS-I-S-1600-060	14.31	14.375 - 14.795	0.375	152	12.12	120	300	1-5/8"	1" MNPT	2200
	80	GS-I-S-1600-080	14.00	14.063 - 14.481	0.375	145	12.12	120	300	1-5/8"	1" MNPT	2300
	100	GS-I-S-1600-100	13.56	13.625 - 14.041	0.375	136	12.12	120	300	1-5/8"	1" MNPT	2350
	120	GS-I-S-1600-120	13.19	13.249 - 13.663	0.375	132	12.12	120	275	1-5/8"	1" MNPT	2400
140	GS-I-S-1600-140	12.75	12.811 - 13.223	0.375	124	12.12	120	275	1-5/8"	1" MNPT	2500	
160	GS-I-S-1600-160	12.44	12.499 - 12.909	0.375	118	12.12	120	275	1-5/8"	1" MNPT	2525	
18	10S	GS-I-S-1800-01S	17.25	17.311 - 17.745	0.375	210	12.12	120	350	1-5/8"	1" MNPT	1725
	10	GS-I-S-1800-010	17.13	17.187 - 17.621	0.375	206	12.12	120	350	1-5/8"	1" MNPT	1750
	20	GS-I-S-1800-020	17.00	17.063 - 17.496	0.375	203	12.12	120	350	1-5/8"	1" MNPT	1775
	STD,40S	GS-I-S-1800-04S	16.88	16.937 - 17.370	0.375	200	12.12	120	350	1-5/8"	1" MNPT	1800
	30	GS-I-S-1800-030	16.75	16.811 - 17.243	0.375	197	12.12	120	350	1-5/8"	1" MNPT	1825
	XS,80S	GS-I-S-1800-08S	16.63	16.687 - 17.118	0.375	195	12.12	120	350	1-5/8"	1" MNPT	1850
	40	GS-I-S-1800-040	16.50	16.563 - 16.994	0.375	192	12.12	120	350	1-5/8"	1" MNPT	1975
	60	GS-I-S-1800-060	16.25	16.311 - 16.740	0.375	186	12.12	120	350	1-5/8"	1" MNPT	2025
	80	GS-I-S-1800-080	15.75	15.811 - 16.238	0.375	180	12.12	120	350	1-5/8"	1" MNPT	2100
	100	GS-I-S-1800-100	15.31	15.375 - 15.800	0.375	175	12.12	120	350	1-5/8"	1" MNPT	2175
	120	GS-I-S-1800-120	15.08	15.137 - 15.561	0.375	170	12.12	120	350	1-5/8"	1" MNPT	2175
140	GS-I-S-1800-140	14.50	14.563 - 14.984	0.375	160	12.12	120	350	1-5/8"	1" MNPT	2275	
160	GS-I-S-1800-160	14.06	14.125 - 14.543	0.375	150	12.12	120	350	1-5/8"	1" MNPT	2350	
20	10S	GS-I-S-2000-01S	19.19	19.249 - 19.693	0.375	265	12.32	120	350	1-5/8"	1-1/2" MNPT	1550
	10	GS-I-S-2000-010	19.13	19.187 - 19.631	0.375	263	12.32	120	350	1-5/8"	1-1/2" MNPT	1550
	20,STD,40S	GS-I-S-2000-04S	18.88	18.937 - 19.380	0.375	256	12.32	120	350	1-5/8"	1-1/2" MNPT	1600
	30,XS,80S	GS-I-S-2000-08S	18.63	18.687 - 19.128	0.375	250	12.32	120	350	1-5/8"	1-1/2" MNPT	1650
	40	GS-I-S-2000-040	18.44	18.499 - 18.939	0.375	245	12.32	120	350	1-5/8"	1-1/2" MNPT	1850
	60	GS-I-S-2000-060	18.00	18.063 - 18.501	0.375	233	12.32	120	350	1-5/8"	1-1/2" MNPT	1875
	80	GS-I-S-2000-080	17.56	17.625 - 18.061	0.375	222	12.32	120	350	1-5/8"	1-1/2" MNPT	1925
	100	GS-I-S-2000-100	17.06	17.125 - 17.558	0.375	210	12.32	120	350	1-5/8"	1-1/2" MNPT	2000
	120	GS-I-S-2000-120	16.63	16.687 - 17.118	0.375	215	12.32	120	350	1-5/8"	1-1/2" MNPT	2050
140	GS-I-S-2000-140	16.12	16.183 - 16.612	0.375	202	12.32	120	320	1-5/8"	1-1/2" MNPT	2075	
160	GS-I-S-2000-160	15.69	15.751 - 16.178	0.375	191	12.32	120	320	1-5/8"	1-1/2" MNPT	2125	
24	10,10S	GS-I-S-2400-010	23.13	23.187 - 23.651	0.375	365	12.32	120	350	1-5/8"	1-1/2" MNPT	1300
	20,STD,40S	GS-I-S-2400-04S	22.88	22.937 - 23.400	0.375	356	12.32	120	350	1-5/8"	1-1/2" MNPT	1325
	XS,80S	GS-I-S-2400-08S	22.63	22.687 - 23.148	0.375	350	12.32	120	350	1-5/8"	1-1/2" MNPT	1350
	30	GS-I-S-2400-030	22.50	22.563 - 23.024	0.375	345	12.32	120	350	1-5/8"	1-1/2" MNPT	1550
	40	GS-I-S-2400-040	22.25	22.311 - 22.770	0.375	338	12.32	120	350	1-5/8"	1-1/2" MNPT	1575
	60	GS-I-S-2400-060	21.69	21.749 - 22.206	0.375	321	12.32	120	350	1-5/8"	1-1/2" MNPT	1625
	80	GS-I-S-2400-080	21.19	21.249 - 21.703	0.375	332	12.32	120	350	1-5/8"	1-1/2" MNPT	1650
	100	GS-I-S-2400-100	20.56	20.625 - 21.076	0.375	321	12.32	120	350	1-5/8"	1-1/2" MNPT	1700
	120	GS-I-S-2400-120	20.00	20.063 - 20.511	0.375	311	12.32	120	350	1-5/8"	1-1/2" MNPT	1725
	140	GS-I-S-2400-140	19.50	19.563 - 20.009	0.375	303	12.32	120	350	1-5/8"	1-1/2" MNPT	1750
160	GS-I-S-2400-160	18.94	18.999 - 19.442	0.375	293	12.32	120	350	1-5/8"	1-1/2" MNPT	1825	

• Larger sizes and custom configurations available upon request. Smaller sizes release date pending.

\* NPS 6-24 TOOL OD MUST BE WITHIN 1/8" CONCENTRICITY TO THE PIPE ID.

• NEVER EXCEED THE MAXIMUM RATED PRESSURE OF THE LOWEST RATED COMPONENT IN THE SYSTEM.

• DATA IS SUBJECT TO CHANGE. Consult manufacturer to verify that this document is the latest release.

**Table 3: Maximum Allowable Pressures (MAP)**

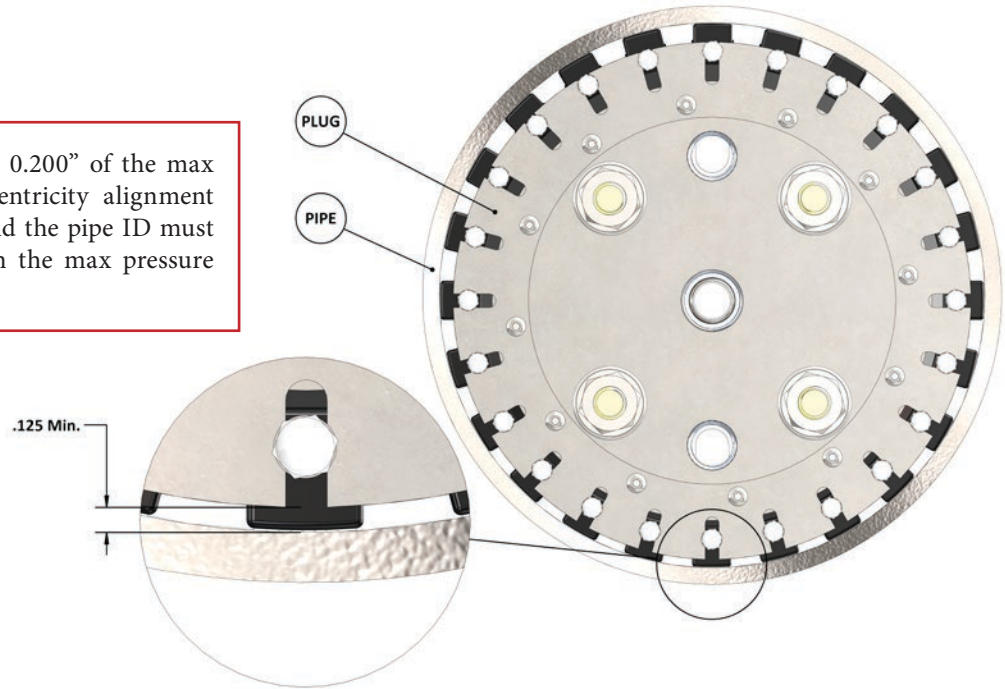
Use the table below to determine the maximum allowable pressure (MAP) the plug and pipe can be subjected to without yielding the pipe. The yield strengths listed in the table correspond to typical minimum yield strengths of standard pipes. If using a Material Test Report (MTR) to determine the yield strength of the pipe or if the pipe yield strength exceeds the highest in the table, the precise MAP can be determined by linear interpolation. **Do not exceed MAX PLUG BACK PRESSURE RATINGS.**

NPS Nominal Pipe Size	PIPE SCHEDULE	MAX PLUG BACK PRESSURE RATING (PSI) (NOT TO EXCEED)	MAXIMUM ALLOWABLE PRESSURE FOR GRIPSAFE PLUGS IN PIPE BASED ON PIPE YIELD STRENGTH - SELECT THE COLUMN BELOW THAT IS LESS THAN OR EQUAL TO PIPE YIELD STRENGTH (PSI) -											
			30000 PSI (A106 A)	35000 PSI (A106 B)	40000 PSI (A106 C)	46000 PSI (X46)	52000 PSI (X52)	60000 PSI (X60)	70000 PSI (X70)	80000 PSI (X80)	90000 PSI (4140HR)	100000 PSI (4140SR)	110000 PSI (P110)	
6	10,10S	3300	725	850	975	1125	1275	1450	1700	1950	2175	2425	2650	
	40,STD,40S	3600	1875	2200	2500	2875	3250	3600	3600	3600	3600	3600	3600	
	80,XS,80S	4000	3475	4000	4000	4000	4000	4000	4000	4000	4000	4000	4000	
	120	3900	3900	3900	3900	3900	3900	3900	3900	3900	3900	3900	3900	
	160	3850	3850	3850	3850	3850	3850	3850	3850	3850	3850	3850	3850	
	XXH	3700	3700	3700	3700	3700	3700	3700	3700	3700	3700	3700	3700	
8	10,10S	3200	500	575	675	775	875	1000	1150	1325	1500	1650	1825	
	20	3350	975	1125	1300	1475	1675	1925	2250	2575	2900	3200	3350	
	30	3400	1100	1300	1475	1700	1925	2200	2575	2950	3300	3400	3400	
	40,STD,40S	3475	1350	1575	1800	2075	2350	2700	3150	3475	3475	3475	3475	
	60	3625	1875	2175	2500	2875	3225	3625	3625	3625	3625	3625	3625	
	80,XS,80S	3800	2525	2950	3375	3800	3800	3800	3800	3800	3800	3800	3800	
	100	3725	3350	3725	3725	3725	3725	3725	3725	3725	3725	3725	3725	
	120	3725	3725	3725	3725	3725	3725	3725	3725	3725	3725	3725	3725	
	140	3925	3925	3925	3925	3925	3925	3925	3925	3925	3925	3925	3925	
	160	3825	3825	3825	3825	3825	3825	3825	3825	3825	3825	3825	3825	
	XXH	3750	3750	3750	3750	3750	3750	3750	3750	3750	3750	3750	3750	
10	10,10S	2725	375	450	500	575	650	750	875	1000	1125	1250	1375	
	20	2800	650	750	850	975	1100	1275	1475	1675	1900	2100	2325	
	30	2875	825	975	1100	1275	1450	1650	1925	2200	2475	2750	2875	
	40,4STD,40s	2950	1050	1225	1400	1600	1825	2100	2450	2775	2950	2950	2950	
	60,XS,80S	3100	1625	1900	2175	2500	2825	3100	3100	3100	3100	3100	3100	
	80	3225	2100	2450	2800	3225	3225	3225	3225	3225	3225	3225	3225	
	100	3400	2825	3275	3400	3400	3400	3400	3400	3400	3400	3400	3400	
	120	3425	3425	3425	3425	3425	3425	3425	3425	3425	3425	3425	3425	
		140,XXH	3475	3475	3475	3475	3475	3475	3475	3475	3475	3475	3475	3475
	160	3475	3475	3475	3475	3475	3475	3475	3475	3475	3475	3475	3475	
12	10,10S	2300	325	375	425	475	525	625	725	825	925	1025	1125	
	20	2375	475	550	625	700	800	925	1075	1225	1375	1525	1675	
	30	2425	675	775	900	1025	1150	1325	1550	1775	1975	2200	2425	
	STD,40S	2475	800	925	1050	1200	1375	1575	1825	2100	2350	2475	2475	
	40	2500	875	1025	1175	1350	1525	1750	2050	2325	2500	2500	2500	
	XS,80S	2575	1175	1375	1575	1800	2025	2350	2575	2575	2575	2575	2575	
	60	2725	1400	1625	1850	2125	2400	2725	2725	2725	2725	2725	2725	
	80	2850	1875	2200	2500	2850	2850	2850	2850	2850	2850	2850	2850	
	100	2900	2575	2900	2900	2900	2900	2900	2900	2900	2900	2900	2900	
		120,XXH	2950	2950	2950	2950	2950	2950	2950	2950	2950	2950	2950	2950
		140	2950	2950	2950	2950	2950	2950	2950	2950	2950	2950	2950	2950
	160	3025	3025	3025	3025	3025	3025	3025	3025	3025	3025	3025	3025	

**Table 3: Maximum Allowable Pressures (MAP) cont.**

NPS Nominal Pipe Size	PIPE SCHEDULE	MAX PLUG BACK PRESSURE RATING (PSI) (NOT TO EXCEED)	MAXIMUM ALLOWABLE PRESSURE FOR GRIPSAFE PLUGS IN PIPE BASED ON PIPE YIELD STRENGTH - SELECT THE COLUMN BELOW THAT IS LESS THAN OR EQUAL TO PIPE YIELD STRENGTH (PSI) -										
			30000 PSI (A106 A)	35000 PSI (A106 B)	40000 PSI (A106 C)	46000 PSI (X46)	52000 PSI (X52)	60000 PSI (X60)	70000 PSI (X70)	80000 PSI (X80)	90000 PSI (4140HR)	100000 PSI (4140SR)	110000 PSI (P110)
14	10S	1925	275	325	375	425	475	550	625	725	800	900	1000
	10	1950	400	450	525	600	675	775	900	1025	1150	1300	1425
	20	1975	525	600	700	800	900	1025	1200	1375	1550	1725	1900
	30,STD,40S	2025	675	775	875	1025	1150	1325	1550	1750	1975	2025	2025
	40	2050	825	950	1100	1250	1425	1625	1900	2050	2050	2050	2050
	XS,80S	2100	1000	1150	1325	1500	1700	1975	2100	2100	2100	2100	2100
	60	2425	1275	1475	1675	1925	2175	2425	2425	2425	2425	2425	2425
	80	2550	1775	2075	2375	2550	2550	2550	2550	2550	2550	2550	2550
	100	2725	2525	2725	2725	2725	2725	2725	2725	2725	2725	2725	2725
	120	2750	2750	2750	2750	2750	2750	2750	2750	2750	2750	2750	2750
140	2800	2800	2800	2800	2800	2800	2800	2800	2800	2800	2800	2800	
160	2825	2825	2825	2825	2825	2825	2825	2825	2825	2825	2825	2825	
16	10S	1950	225	250	300	325	375	425	500	575	650	700	775
	10	1975	300	350	400	475	525	600	700	800	900	1000	1100
	20	2000	425	475	550	625	700	825	950	1075	1225	1350	1475
	30,STD,40S	2025	525	600	700	800	900	1025	1200	1375	1550	1725	1900
	40,XS,80S	2100	775	900	1025	1175	1325	1525	1775	2050	2100	2100	2100
	60	2200	1125	1325	1500	1725	1950	2200	2200	2200	2200	2200	2200
	80	2300	1650	1925	2200	2300	2300	2300	2300	2300	2300	2300	2300
	100	2350	2250	2350	2350	2350	2350	2350	2350	2350	2350	2350	2350
	120	2400	2400	2400	2400	2400	2400	2400	2400	2400	2400	2400	2400
	140	2500	2500	2500	2500	2500	2500	2500	2500	2500	2500	2500	2500
160	2525	2525	2525	2525	2525	2525	2525	2525	2525	2525	2525	2525	
18	10S	1725	175	200	225	275	300	350	400	450	525	575	625
	10	1750	250	300	325	375	425	500	575	650	750	825	900
	20	1775	325	400	450	500	575	650	775	875	975	1100	1200
	STD,40S	1800	425	500	550	650	725	825	975	1100	1250	1375	1525
	30	1825	525	600	700	800	900	1025	1200	1375	1550	1700	1825
	XS,80S	1850	625	725	825	950	1075	1225	1450	1650	1850	1850	1850
	40	1975	725	850	975	1125	1275	1450	1700	1950	1975	1975	1975
	60	2025	1100	1300	1475	1700	1925	2025	2025	2025	2025	2025	2025
	80	2100	1550	1800	2075	2100	2100	2100	2100	2100	2100	2100	2100
	100	2175	2150	2175	2175	2175	2175	2175	2175	2175	2175	2175	2175
120	2175	2175	2175	2175	2175	2175	2175	2175	2175	2175	2175	2175	
140	2275	2275	2275	2275	2275	2275	2275	2275	2275	2275	2275	2275	
160	2350	2350	2350	2350	2350	2350	2350	2350	2350	2350	2350	2350	
20	10S	1550	175	200	225	275	300	350	400	450	525	575	625
	10	1550	200	250	275	325	350	400	475	550	600	675	750
	20,STD,40S	1600	350	400	475	525	600	700	800	925	1025	1150	1250
	30,XS,80S	1650	525	600	675	775	875	1025	1200	1350	1525	1650	1650
	40	1850	650	775	875	1000	1125	1300	1525	1725	1850	1850	1850
	60	1875	1025	1200	1375	1575	1775	1875	1875	1875	1875	1875	1875
	80	1925	1475	1725	1925	1925	1925	1925	1925	1925	1925	1925	1925
	100	2000	2000	2000	2000	2000	2000	2000	2000	2000	2000	2000	2000
	120	2050	2050	2050	2050	2050	2050	2050	2050	2050	2050	2050	2050
	140	2075	2075	2075	2075	2075	2075	2075	2075	2075	2075	2075	2075
160	2125	2125	2125	2125	2125	2125	2125	2125	2125	2125	2125	2125	
24	10,10S	1300	150	175	200	225	250	300	350	400	450	500	550
	20,STD,40S	1325	250	300	350	400	450	500	575	675	750	825	925
	XS,80S	1350	375	425	500	575	650	750	850	975	1100	1225	1350
	30	1550	450	500	575	675	750	875	1000	1150	1300	1450	1550
	40	1575	575	675	775	875	1000	1150	1350	1525	1575	1575	1575
	60	1625	950	1125	1275	1450	1625	1625	1625	1625	1625	1625	1625
	80	1650	1350	1575	1650	1650	1650	1650	1650	1650	1650	1650	1650
	100	1700	1700	1700	1700	1700	1700	1700	1700	1700	1700	1700	1700
	120	1725	1725	1725	1725	1725	1725	1725	1725	1725	1725	1725	1725
	140	1750	1750	1750	1750	1750	1750	1750	1750	1750	1750	1750	1750
160	1825	1825	1825	1825	1825	1825	1825	1825	1825	1825	1825	1825	

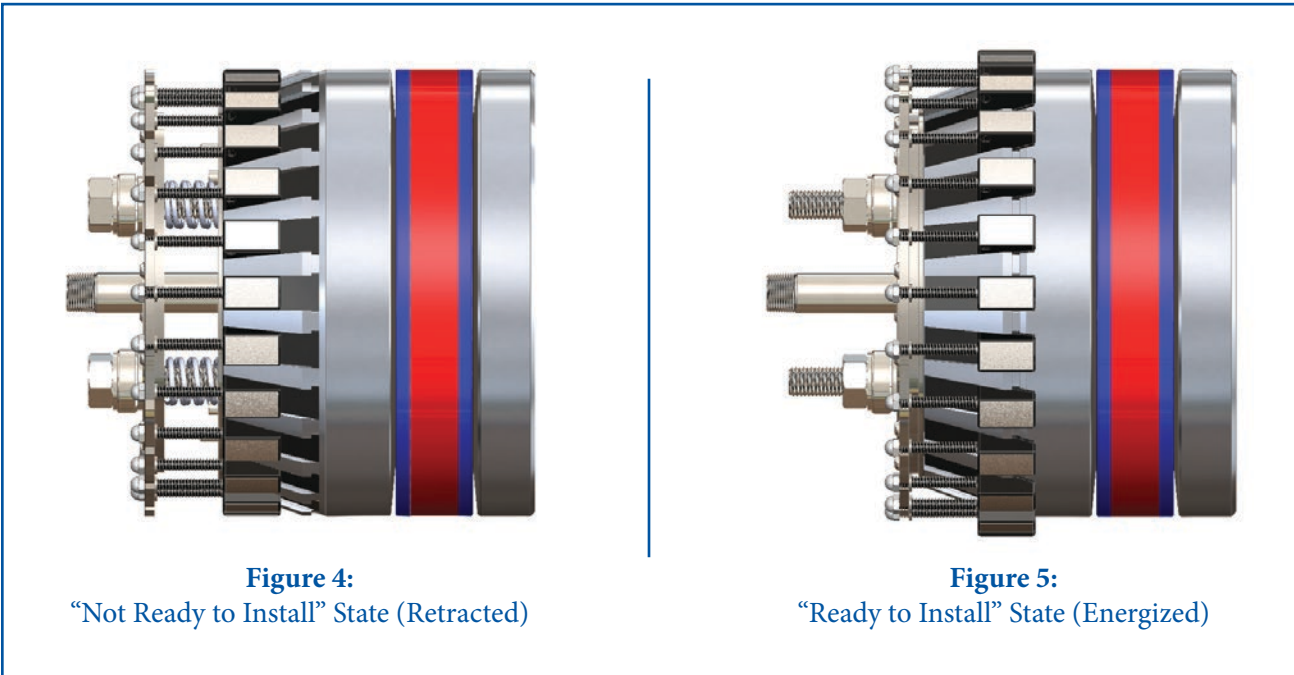
If the pipe ID is within 0.200" of the max ID Range, a 1/8" concentricity alignment between the plug OD and the pipe ID must be maintained to obtain the max pressure rating.



**Figure 3:** GripSafe Plug and Pipe Concentricity

## 5. Preparing the GripSafe ORB Plug for Installation

5.1 The GripSafe ORB should be in the “Ready to Install” position from the factory.



**Figure 4:**  
“Not Ready to Install” State (Retracted)

**Figure 5:**  
“Ready to Install” State (Energized)


- Ensure the *Compression Hex Nuts(19)* are tightened to the point where the *Spring Plate Hub(17)* is in the energized state, flush to the *Retainer Plate(15)*.
- Do not over tighten or torque nuts to the point that the *Seal(9)* starts to swell or extrude over the OD of the plug.
- In the “Ready to Install” state (see **Figure 5**) the GripSafe plug will immediately grip the pipe upon insertion.



**CAUTION:** Make sure plug is clean of debris and contaminants. Each *Wedge Gripper(3)* should slide freely up and down in its slot with a full range of motion and no resistance. *Wedge Grippers(3)* with impeded movement due to debris, dirt or contaminants will cause the plug to not grip on the pipe’s ID which can cause it to eject under pressure, potentially leading to injury or death, material loss, and/or damage to equipment.

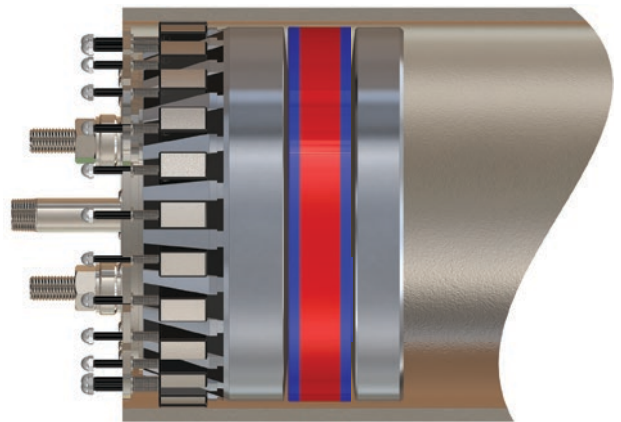
## 6. Installing the GripSafe ORB Plug



**CAUTION:** Ensure pipe I.D. is clean, and loose debris is removed to the deepest point the plug will be installed into. If the pipe is lined or has an unremovable product,  and **contact USA Industries, Inc. for support before proceeding.** Failure to do so may impede the wedges ability to grip and cause the plug to eject under pressure. Be sure to wear proper PPE and follow all site guidelines.

### 6.1 Insert the GripSafe ORB plug evenly into the pipe.

- See *Table 2* for Operational ID Range and clearance requirements.
- For using GripSafe *Lifting Device*, see **Section 8**.
- When the *Gripping Wedges(3)* come into contact with the pipe I.D., evenly push the GripSafe ORB plug further into the pipe.
- A slight rocking motion will assist in insertion.
- Once the *Gripping Wedges(3)* have begun entering the pipe, each will be in independent contact with the pipe I.D. Retraction or removal of the plug at this juncture is not possible unless the *Compression Nuts(19)* are loosened (see **Section 7** for plug removal).
- Insert plug until the top of the *Spring Plate Hub(17)* is at least flush with the end of the pipe (see **Figure 6**).



**Figure 6:** GripSafe ORB Minimum Insertion Depth in a Sectioned Pipe

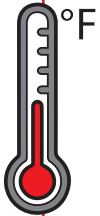


- If insertion into the pipe proves problematic in the “Ready to Install” state (see **Figure 5**), it may be advantageous to insert the plug in the “Not Ready to Install” states (see **Figure 4**). To do so, loosen all *Compression Hex Nuts*(19) to the top of their respective *All-Thread Shafts*(7). Care should be taken to not completely remove the *Compression Hex Nuts*(19) from the assembly. In this orientation, the *Gripping Wedges*(3) will be fully retracted and the plug can be inserted freely into the pipe.



**CAUTION:** In this orientation, it is important to note the plug will not be immediately gripping the pipe upon insertion. Only after tightening the *Compression Hex Nuts*(19) while the plug is in the pipe, to advance the bottom of the *Spring Plate Hub*(17) to contact the top of the *Retainer Plate*(15) will the plug be securely gripping the pipe. Continue installation with **Step 6.2**.

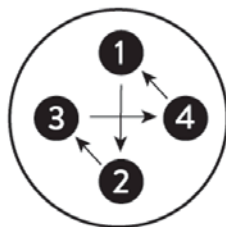
**TEMPERATURE NOTE:**



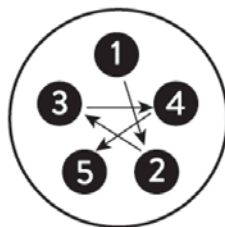
If welding is to occur on the pipe while the plug is installed the front face of the plug (*Spring Plate Hub*(17)) should be installed a minimum of 6” from the center of an active weld to prevent the *Seals* (*Tri-Ply*™)(9) from degrading or ultimately failing due to melting. For post weld heat treats, bake-outs, etc., the plug should be at least 12” from the nearest edge of the heating element, and the temperature at the depth the plug is installed at should not exceed 220°F. If a high temperature bake out is being performed (400°F or higher) increase the installation depth as much as possible. In all cases, monitor the pressure behind the plug and/or between the seals at all times and stop work immediately if any pressure drop is detected. In addition, the pipes external surface temperature should be monitored corresponding to the plugs seal location at all times to ensure damage to the seals does not occur.

**6.2 Evenly tighten the Compression Nuts(19).**

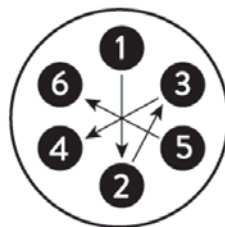
- Using a star pattern (see **Figure 7**), turn each *Compression Hex Nut*(19) a maximum of 3 full revolutions before moving to the next nut. Repeat until 50% target torque is achieved on all nuts, and then increase to 100% target installation torque and continue torqueing in a star pattern. After completing the star pattern at 100% of the target torque, use a circular pattern to confirm all nuts are torqued correctly.
- Minimal torque will be required for the first several passes, but torque will increase notably after the *Seal*(9) begins to compress against the pipe ID.



**4** Compression Hex Nut Tightening Pattern



**5** Compression Hex Nut Tightening Pattern



**6** Compression Hex Nut Tightening Pattern



**8** Compression Hex Nut Tightening Pattern

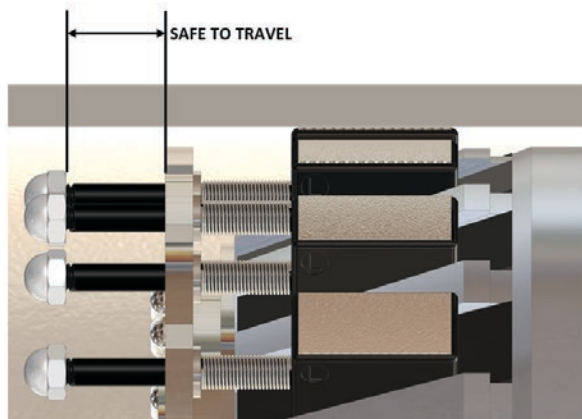




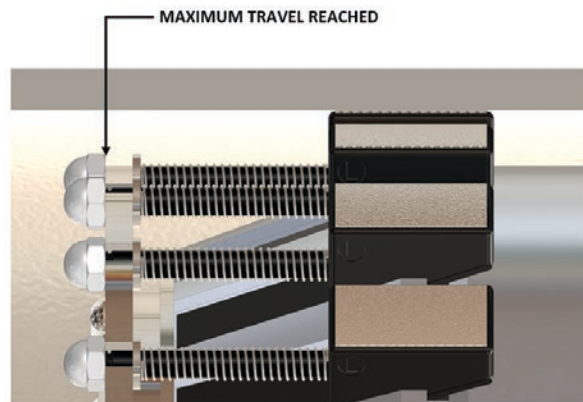
**NOTE:** To help center the plug in the pipe it may be desirable to tighten the two bottom-most *Compression Hex Nuts(19)* to expand the *Seal(9)* under them, thereby lifting the plug up to center. A short push of the plug will reset the *Wedge Grippers(3)* to accommodate the new centered position respective to the rest of the plug body. Normal installation should commence once the plug is centered. This may be desirable in the event the plug is noticeably not in the center of the pipe and test pressures are not achieved while the plug is at **Maximum Compression Torque** or the plug is not within the 1/8" concentricity limit if the pipe ID is within 0.200" of maximum range.

### 6.3 Verify integrity of the Seal(9).

- If the plug is being used for pressure testing, use proper fittings to install a hydro test pump to the *Back Pressure Vent Port(16)*; otherwise, install a cap to seal off the system or a back pressure monitoring tee.
- Increase pressure to 25% of target pressure or 150 psig, whichever is less. A drop in pressure may not be an indication of leakage. *GripSafe Seals(9)* will creep under pressure until they are fully seated. This creep will increase the pressure test volume. Depending on the test volume size this may be by such a trivial amount it will not be seen on a gauge. For relatively small test volumes a noticeable gradual loss in pressure may be observed during this creep phase. Seating the *Seal(9)* is obtained by reapplying pressure until the pressure becomes stable. This seal creep may also be observed when the system is subjected to the full pressure. Resolution to the creep is the same at high pressure and while verifying integrity.



**Figure 8:** *Wedge Grippers* Safe to Travel



**Figure 9:** *Wedge Grippers* Maximum Travel Reached



**CAUTION:** If the plug is being used for pressure testing, carefully observe the *Wedge Gripper Nuts(1)* travel. In **Figure 8**, pressure can be added to the system since the *Wedge Gripper Nuts(1)* are still far from the *Spring Plate Halo(13)*. In **Figure 9** however, no additional pressure can be added to the system since the *Wedge Gripper Nuts(3)* have reached their maximum travel.



**CAUTION:** Careful observation is needed at the location of the pipe where the *Wedge Grippers* make contact while performing a hydro test. If any deformation or swelling of the pipe is observed, **STOP IMMEDIATELY** and slowly release the pressure from the system. **Contact USA Industries for further assistance.**

- It may be desirable to attach a gauge and vent hose assembly, or a back pressure monitoring tee, to the *Back Pressure Vent Port(16)* to bleed off any back pressure. The hose should be long enough to redirect vapor coming out of the vessel to a safe location away from personnel that may be in the area. A valve may also be attached to this port to allow safe back pressure removal before plug extraction (see **Section 7**). If using a back pressure monitoring tee, it may be useful to have a pressure gauge on the branch side of the tee while connecting the run side to the *Back Pressure Vent Port(16)* and a ball valve. Further advantages can be made by attaching a hose to the ball valve on the monitoring tee and running the hose to vent to a safe location away from workers that may be in the area.



**CAUTION:** Fast flowing gases or liquids through hosing can cause hose whip. Take caution to avoid this, failure to do so may result in injury and/or equipment damage.



**CAUTION:** Do not stand directly in front of the GripSafe ORB plug at any time. Installed plugs should always be treated in this manner irrespective if the plug has back pressure on it or not.



**CAUTION:** If back pressure develops, constant observation of pressure observed through the use of an attached gauge and physical observation of pipe integrity is necessary to ensure safety to personnel and equipment. Any bulging, enlargement or tapering of the pipe is an indication of over pressuring. The back pressure Rating listed in *Table 1* is for the pressure holding capability of the GripSafe ORB and could be well beyond the system design limitations in which it is being used to test.

#### 6.4 The GripSafe plug is now ready to accept back pressure. Observe pressure ratings listed in Table 3.



**CAUTION:** If at any time during hydro testing a popping or clicking sound is heard, **STOP IMMEDIATELY** and slowly release the pressure from the system. Popping or clicking sounds during hydro testing could be a sign of the *Wedge Gripper* slipping, cracking, or one of the plug components failing. Remove the plug from the pipe or fitting and inspect for damage. **Contact USA Industries for further assistance.**



**CAUTION: REFER TO TABLE 3: MAXIMUM ALLOWABLE PRESSURE** in this manual; **DO NOT EXCEED** the pressure ratings identified in the table when pressurizing the pipe. Careful observation is needed at the location of the pipe where the *Wedge Grippers* make contact while performing a hydro test. If any deformation or swelling of the pipe is observed, **STOP IMMEDIATELY** and slowly release the pressure from the system. **Contact USA Industries for further assistance.**

## 7. GripSafe ORB Plug Removal

- 7.1 Depressurize the system through the hydro test pump or a valve on the back pressure monitoring tee and drain all water.
- 7.2 Ensure there is no back pressure on the GripSafe ORB plug.



**CAUTION: SLOWLY** open the *Vent Port(16)* to relieve back pressure. Care must be taken when opening valves or loosening fittings if inadvertent back pressure was introduced into the vessel. Failure to do so may result in hazardous pressure flow and/or fittings becoming hazardous projectiles that may cause injury and/or equipment damage. If utilizing a back pressure monitoring tee, fast flowing gases or liquids through hosing can cause hose whip. Take caution to avoid this, failure to do so may result in injury and/or equipment damage.

- 7.3 Loosen the *Compression Hex Nuts(19)* in an even star pattern so as to not place the whole load on one bolt.

- If a *Compression Hex Nut(19)* runs free during loosening, run the nut back to flush with the top of the *Spring Plate*. The *Seal(9)* acts as a spring containing a large amount of force too great for one *All-Threaded Shaft(7)* to handle.
- After the *Seal(9)* has fully decompressed, the torque required will be notably less.
- Once the *Seal(9)* has broken free from the pipe ID, continue loosening the *Compression Hex Nuts(19)* until they are even with the top of the *All-Threaded Shaft(7)*.



**NOTE:** Do not remove the *Compression Hex Nut(19)* from the bolt. If this happens, **IMMEDIATELY REINSTALL THE COMPONENTS.**



**CAUTION:** Ensure that all *Compression Hex Nuts(19)* maintain a load on them during the entire loosening process. Having all *Compression Hex Nuts(19)* loose, with the exception of one, means that a large load is left on the one *Compression Bolt*, and the risk of breakage is high. Once the *Seal(9)* is relaxed enough to break the seal from the pipe ID, the plug is now in a more relaxed state and *Compression Hex Nuts(19)* can be loosened in full.

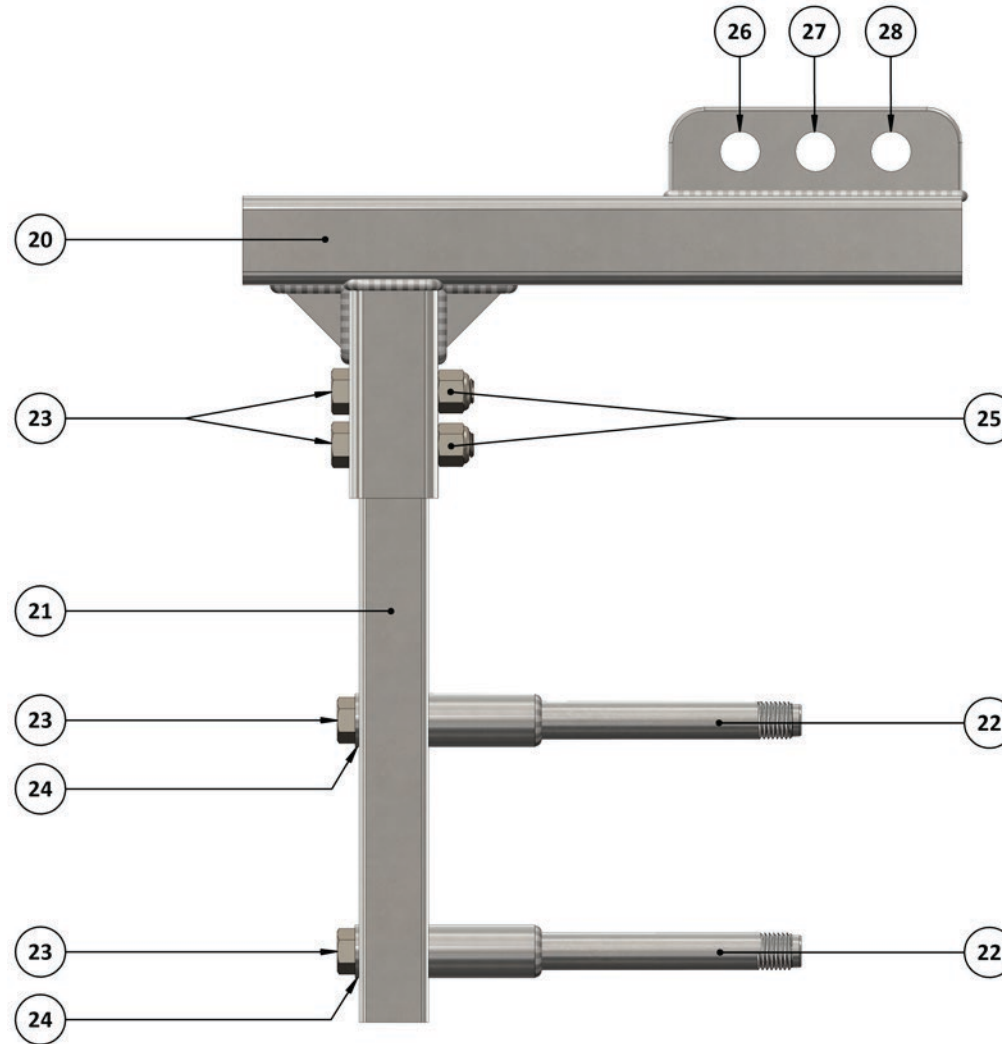
- 7.4 Remove the GripSafe ORB plug from the pipe.

- Clean and store for later use or return to USA Industries, Inc.
- Thoroughly dry and apply rust-preventative oil to the *Thrust Bearing(18)* before storing.
- Store out of direct sunlight, and in an area not exposed to temperatures above 150°F. UV. Excessive heat will cause the *Seal(9)* to degrade over time.



- The *Wedge Gripper(3)* texture (*Gritlock™*) may become packed with pipe scale and rust after several uses of the plug. Inspect this surface after each use in order to keep the gripping strength at peak performance. To clean, simply use mild dishwashing soap and a stiff stainless steel bristled brush such as a welding brush. If packing is persistent, use of a household rust remover along with a stiff stainless steel bristled brush should be sufficient. Rinse plug clean of residual chemicals with tap water and dry thoroughly.

## 8. GripSafe Lifting Device





**Table 4: Lifting Device Bill of Materials**

Plug Size	⑳	㉑	㉑	㉑	㉒	㉒	㉔	㉕	㉖
	Universal Lifting Bar	Telescoping Lifting Attachment #1	Telescoping Lifting Attachment #2	Telescoping Lifting Attachment #3	Lifting Standoff #1	Lifting Standoff #2	Lifting Device Bolt	Lifting Device Washer	Lifting Device Nut
10	1	1	N/A	N/A	2	N/A	4	2	2
12	1	1	N/A	N/A	2	N/A	4	2	2
14	1	N/A	1	N/A	N/A	2	4	2	2
16	1	N/A	1	N/A	N/A	2	4	2	2
18	1	N/A	1	N/A	N/A	2	4	2	2
20	1	N/A	N/A	1	N/A	2	4	2	2
24	1	N/A	N/A	1	N/A	2	4	2	2
30	1	N/A	N/A	N/A	N/A	2	4	2	2
36	1	N/A	N/A	N/A	N/A	2	4	2	2



## 8.1 Installing the lifting device on the GripSafe ORB plug.

- Insert the *Lifting Standoffs(22)* into the two holes located on top of the *Spring Plate Hub(17)*. Hand tighten both *Lifting Standoffs(22)* until they bottom out (see **Figure 11**).



**CAUTION:** A minimum of 6 full turns is needed when threading both the *Lifting Standoffs(22)* into the GripSafe ORB plug. Failure to follow this step may cause the *Lifting Threads* to fail under the load of the plug, causing it to fall, injuring personnel and/or damage to equipment.

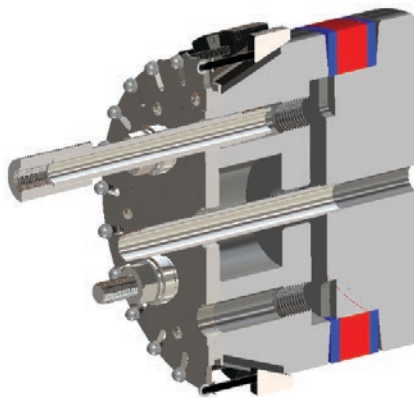


**NOTE:** There are two types of *Lifting Standoffs(22)*, #1 and #2. #1 is used for plugs 10”- 12” and #2 is used for plugs 14” and over.

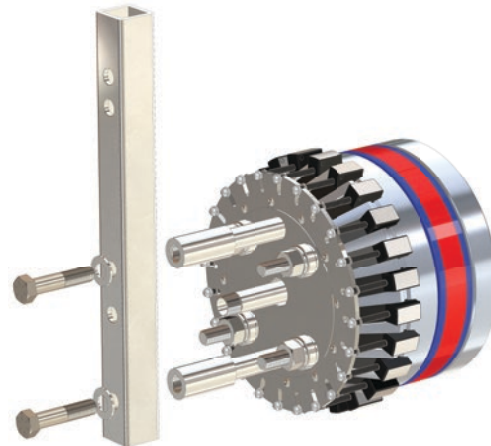
- Line up the holes on the *Telescoping Lifting Attachment(21)* with the internally threaded holes on the *Lifting Standoffs(22)*. Fasten the *Telescoping Lifting Attachment(21)* on to the *Lifting Standoffs (22)* with the provided *Lifting Device Bolts(24)* and *Washers(25)* (see **Figure 12**).



**NOTE:** There are 3 types of *Telescoping Lifting Attachments(21)*, #1, #2, and #3. Each have different lengths and mounting hole locations to accommodate distinct plug sizes. Refer to Table 5 for details.

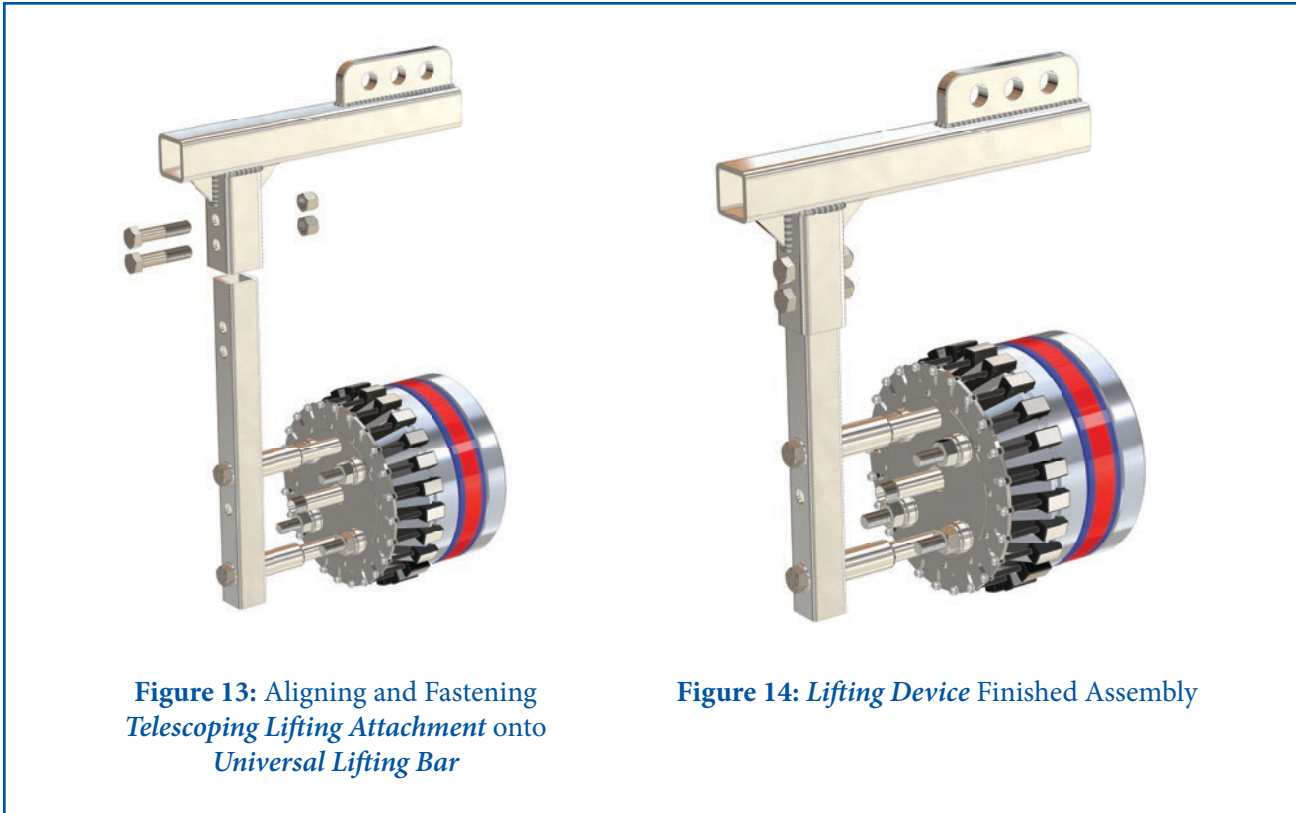


**Figure 11:** Inserting and Threading *Lifting Standoffs* into the Plug



**Figure 12:** Aligning and Fastening *Telescoping Lifting Attachment* onto *Lifting Standoffs*

- After fastening the *Telescoping Lifting Attachment(21)* to the *Lifting Standoffs(22)*, slide it into the *Universal Lifting Bar's(20)* shorter square tubing. Upon insertion, align the two holes on both the *Telescoping Lifting Attachment(21)* and *Universal Lifting Bar(20)*.
- Fasten the *Telescoping Lifting Attachment (21)* with the provided *Lifting Bolts(24)* and *Nuts(26)* (see **Figure 13**).



## 8.2 Using Lifting Device.

- There are three *Anchor Holes*(26),(27),and (28) on the *Lifting Device*. Use one or two of the three anchor holes to orient the GripSafe ORB plug horizontally.
- If none of the three holes comes close to the center gravity of the plug, a *Cheater Bar* may be inserted in the long square tubing portion of the *Universal Lifting Bar*(20) and used as leverage. A *Cheater Bar* can also be used to help manipulate the plug while inserting it into the pipe.



GripSafe is a registered trademark of USA Industries, Inc.