



# GRIPSAFE<sup>®</sup> ST

## INSTALLATION MANUAL



---

### Small Outboard Retraction Blocking (ORB) Plug

$\frac{3}{4}$ " – 4"\*

\*For 4" Schedules 120, 160 and XXH only. Additional 4" Schedules Require the GripSafe ST Large ORB Plug

---

Manufactured Exclusively by USA Industries, an ISO  
9001:2015 Certified Company

For patent and trademark information, go to  
<https://www.USAIindustries.com/gripsafe-patents/trademarks/>

**[www.USAIindustries.com](http://www.USAIindustries.com)**  
**(713) 941-3797 • (800) 456-8721**  
315 State Street • S. Houston, TX 77587

## Table of Contents

---



1. Introduction.....	1
2. Safety .....	2
3. Parts .....	3
4. Specifications .....	6
5. Preparing the GripSafe ST ORB Plug for Installation .....	8
6. Installing the GripSafe ST ORB Plug.....	10
7. GripSafe ST ORB Plug Removal.....	13
8. Installing and Using Safety Gag .....	14

## 1. Introduction

---

Thank you for choosing GripSafe ST pipe plugging technology. This manual covers the proper use of this technology to ensure safe operating conditions. All necessary sockets and wrenches to install this equipment are available for rental/purchase from USA Industries, LLC. See **Section 4 Table 2** for sockets.

The information in this manual is intended for the use of a GripSafe ST IIB plug in metallic piping. If the intended use of this plug is for any piping other than metallic piping please contact USA Industries Customer Service Department for technical support.

-  **Do not use GripSafe ST equipment before fully reading and comprehending and comprehending this manual**
-  **Failure to follow this manual in full may result in injury to personnel and damage to equipment.**

## 2. Safety

---

- ⚠ Failure to follow proper safety requirements may result in the GripSafe ST ORB plug failing, which could lead to personnel injury, material loss, and damage to equipment.
- ⚠ Wear proper PPE when performing any task with the GripSafe ST ORB plug as defined by site safety rules. Always follow site procedure for safely lifting and operating equipment.
- ⚠ Never install the GripSafe ST ORB plug in a position where the Gripping Wedge would be located over weld droop or ridge.
- ⚠ Never install the Seals or Gripping Wedge over a section of pipe that is missing its interior wall; e.g. weldolet, tee, etc.
- ⚠ Use care in the handling of the Wedge Studs. Never beat, hammer, or pry on the Wedge Studs. Never remove the nut located on the Wedge Studs.
- ⚠ Pressure testing can be an extremely hazardous operation and safety precautions should be strictly adhered to. Never stand or pass in front of any test plug while installed or while testing is in progress.
- ⚠ Do not make any adjustments to the plug, safety equipment, or vessel while the plug is under pressure.
- ⚠ Do not exceed rated pressure stamped on the plug. Plugs are rated for holding pressure in one direction only, never apply pressure on the non-rated side of the plug.
- ⚠ Backpressure rating on the plug is in reference to the plugs ultimate holding capacity. Never exceed the pressure capacity of the weakest component in a pressurized system. It is imperative that a system's components be studied prior to beginning a pressure test to confirm the maximum test pressure a system can be subjected to in accordance with all applicable industry and site-specific standards.
- ⚠ It is recommended that water be used as the test medium. Venting all gases from the vessel being pressurized is necessary before pressurizing the system.
- ⚠ In the event pneumatic testing is required, all attempts to limit potential damage to any personnel or equipment must be made. USA Industries recommends Nitrogen as the medium for pneumatic testing as it does not support combustion. Follow provisions outlined in ASME PCC-2 Repair of Pressure Equipment and Piping when testing pneumatically.
- ⚠ The Outboard Retraction Blocking GripSafe ST ORB plug is designed to hold pressure originating from the vessel side only.
- ⚠ Careful observation is needed at the location of the pipe where the Wedge Grippers make contact while performing a hydrotest. If any deformation or swelling of the pipe is observed, stop immediately and slowly release the pressure from the system. Contact USA Industries for further assistance.
- ⚠ At any time during hydrotesting, if a popping or clicking sound is heard, stop immediately and slowly release the pressure from the system. Popping or clicking sounds during hydrotesting could be a sign of the Wedge Gripper slipping, cracking, or plug components failing. Remove the plug from the pipe or fitting and inspect for damage. Contact USA Industries for further assistance.
- ⚠ Ensure plug is clean of debris, fouling, and contaminants before each use. Each Wedge Grippers should freely slide up and down in its slots with a full range of motion without any resistance. With impeded movement due to debris, dirt, contaminants, or other fouling will cause the plug to not grip on the pipe's inner diameter, which can cause it to eject under pressure, leading to personnel injury or death, material loss, and damage to equipment.
- ⚠ For any questions or concerns, contact USA Industries for technical assistance.

### 3. Parts

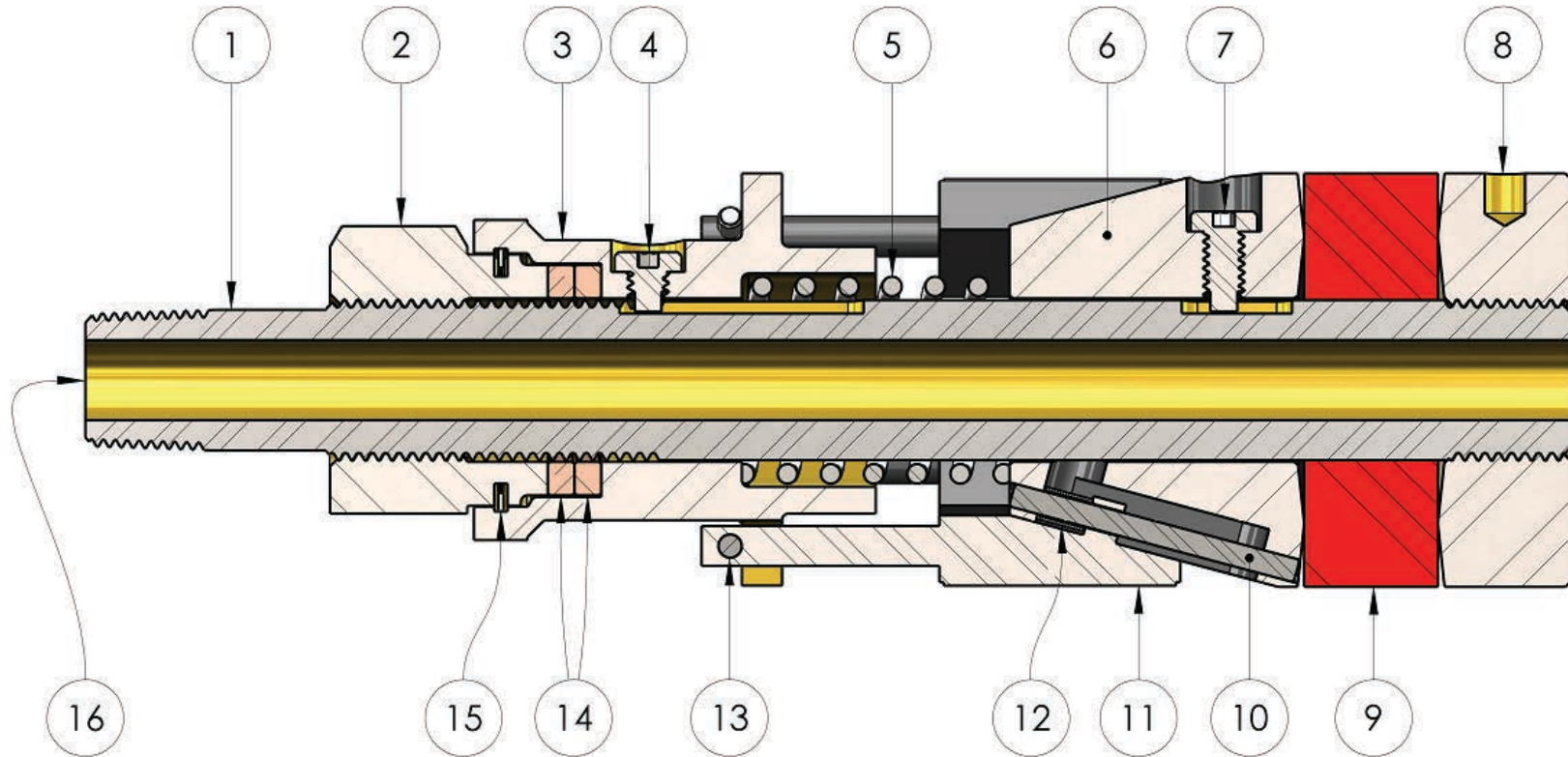

Figure 1: GripSafe ST Outboard Retraction Blocking 3/4" - 2" (ORB) Diagram



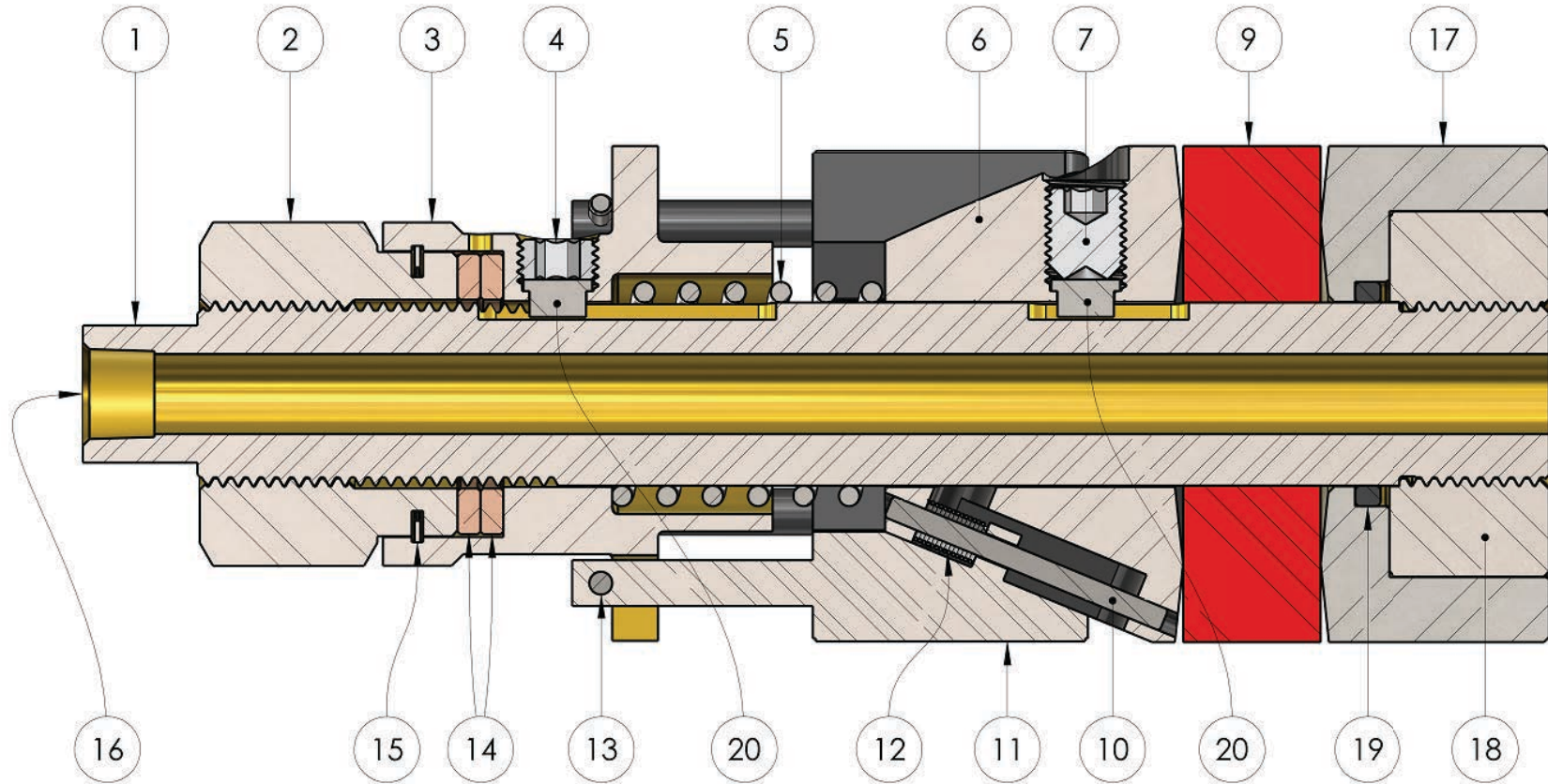

Figure 2: GripSafe ST Outboard Retraction Blocking 2-1/2" – 4" (ORB) Diagram

**Table 1: GripSafe ST ORB Plug Bill Of Materials**

Nominal Pipe Size (in)	Schedule	(1)	(2)	(3)	(4)	(5)	(6)	(7)	(8)	(9)	(10)	(11)	(12)	(13)	(14)	(15)	(16)	(17)	(18)	(19)	(20)
		Shaft	Compression Hex Nut	ORB Spring Plate	Spring Plate Alignment Screw	Retraction Spring	Wedge Cone	Wedge Cone Alignment Screw	Bottom Compression Plate	Seal	Wedge Gripper Dowel Pin	Wedge Gripper	Wedge Gripper Spring	Wedge Gripper Retaining Dowel Pin	Thrust Bearing	ORB Retaining Ring	Vent Port	Sealing Compression Ring	O-Ring Compression Threaded Insert	Compression Ring O-Ring	Spring Plate and Wedge Cone Alignment Key
3/4	40,STD,40S	1	1	1	0	1	1	1	1	1	5	5	5	5	1	1	1	0	0	0	0
	80,XS,80S	1	1	1	0	1	1	1	1	1	5	5	5	5	1	1	1	0	0	0	0
1	10	1	1	1	0	1	1	1	1	1	6	6	6	6	2	1	1	0	0	0	0
	40,STD,40S	1	1	1	0	1	1	1	1	1	5	5	5	5	2	1	1	0	0	0	0
	80,XS,80S	1	1	1	0	1	1	1	1	1	5	5	5	5	2	1	1	0	0	0	0
	160	1	1	1	0	1	1	1	1	1	5	5	5	5	1	1	1	0	0	0	0
1-1/4	10	1	1	1	1	1	1	1	1	1	7	7	7	7	2	1	1	0	0	0	0
	40,STD,40S	1	1	1	1	1	1	1	1	1	6	6	6	6	2	1	1	0	0	0	0
	80,XS,80S	1	1	1	1	1	1	1	1	1	5	5	5	5	2	1	1	0	0	0	0
	160	1	1	1	0	1	1	1	1	1	6	6	6	6	2	1	1	0	0	0	0
1-1/2	10	1	1	1	1	1	1	1	1	1	7	7	7	7	2	1	1	0	0	0	0
	40,STD,40S	1	1	1	1	1	1	1	1	1	6	6	6	6	2	1	1	0	0	0	0
	80,XS,80S	1	1	1	1	1	1	1	1	1	5	5	5	5	2	1	1	0	0	0	0
	160	1	1	1	1	1	1	1	1	1	6	6	6	6	2	1	1	0	0	0	0
2	10	1	1	1	1	1	1	1	1	1	7	7	7	7	2	1	1	0	0	0	0
	40,STD,40S	1	1	1	1	1	1	1	1	1	6	6	6	6	2	1	1	0	0	0	0
	80,XS,80S	1	1	1	1	1	1	1	1	1	6	6	6	6	2	1	1	0	0	0	0
	160	1	1	1	1	1	1	1	1	1	7	7	7	7	2	1	1	0	0	0	0
	XX	1	1	1	1	1	1	1	1	1	5	5	5	5	2	1	1	0	0	0	0
2-1/2	10	1	1	1	1	1	1	1	1	1	7	7	7	7	2	1	1	1	1	1	2
	40,STD,40S	1	1	1	1	1	1	1	1	1	6	6	6	6	2	1	1	1	1	1	2
	80,XS,80S	1	1	1	1	1	1	1	1	1	6	6	6	6	2	1	1	1	1	1	2
	160	1	1	1	1	1	1	1	1	1	7	7	7	7	2	1	1	0	0	0	0
	XX	1	1	1	1	1	1	1	1	1	7	7	7	7	2	1	1	0	0	0	0
3	10	1	1	1	1	1	1	1	1	1	8	8	8	8	2	1	1	1	1	1	2
	40,STD,40S	1	1	1	1	1	1	1	1	1	7	7	7	7	2	1	1	1	1	1	2
	80,XS,80S	1	1	1	1	1	1	1	1	1	7	7	7	7	2	1	1	1	1	1	2
	160	1	1	1	1	1	1	1	1	1	7	7	7	7	2	1	1	1	1	1	2
	XX	1	1	1	1	1	1	1	1	1	7	7	7	7	2	1	1	1	1	1	2
3-1/2	10	1	1	1	1	1	1	1	1	1	8	8	8	8	2	1	1	1	1	1	2
	40,STD,40S	1	1	1	1	1	1	1	1	1	7	7	7	7	2	1	1	1	1	1	2
	80,XS,80S	1	1	1	1	1	1	1	1	1	7	7	7	7	2	1	1	1	1	1	2
	XX	1	1	1	1	1	1	1	1	1	6	6	6	6	2	1	1	1	1	1	2
4	120	1	1	1	1	1	1	1	1	1	7	7	7	7	2	1	1	1	1	1	2
	160	1	1	1	1	1	1	1	1	1	7	7	7	7	2	1	1	1	1	1	2
	XX	1	1	1	1	1	1	1	1	1	7	7	7	7	2	1	1	1	1	1	2

## 4. Specifications

---

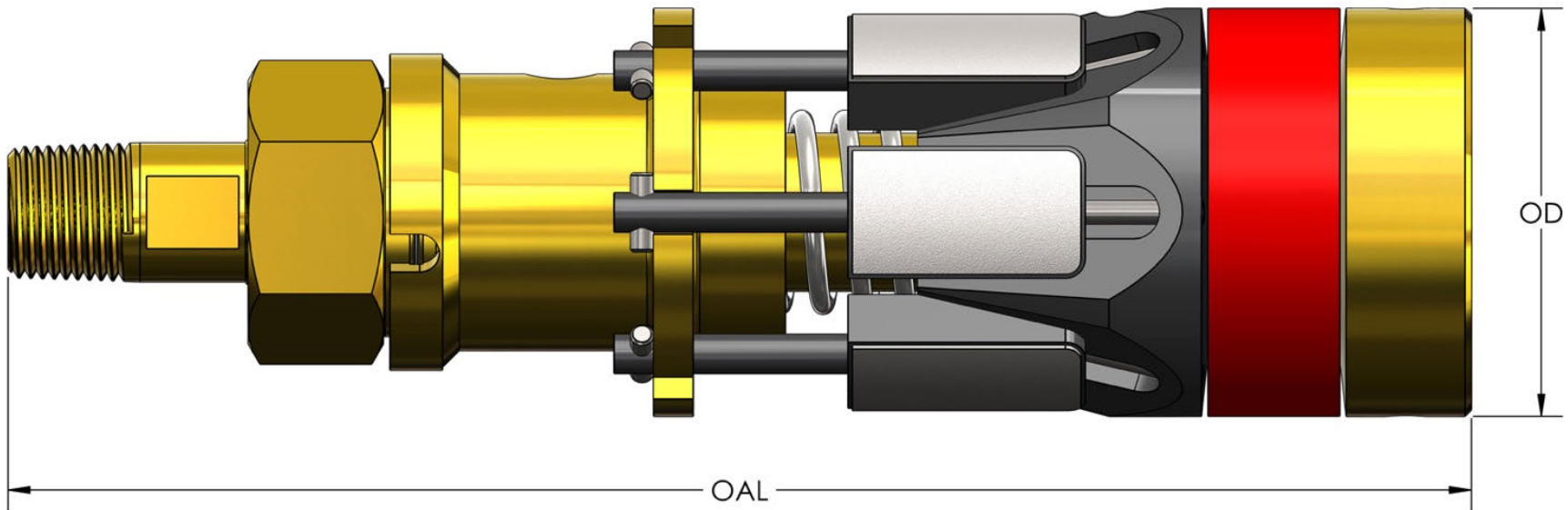

Figure 3: GripSafe ST Outboard Retraction Blocking Diagram Dimensions

**Table 2: GripSafe ST ORB Plug Specifications**

Nominal Pipe Size (in)	Schedule	Part Number	Tool Diameter (in)	Rec. ID Range* (in)	Nominal Pipe ID Clearance (in)	Approx. Tool Weight (lbs)	Tool Length (in)	Torque Range (ft-lbs)		Compression Hex Nut Size (in)	Backup Wrench Size (in)	Back Pressure Vent Thread	Back Pressure Rating (psi)
								Norm	Max.				
3/4	40,STD,40S	GSST-I-S-0075-040	0.79	0.80 - 0.87	0.035	0.3	4.15	2.9	4.5	1/2	1/4 Open End	1/4 MNPT	10000
	80,XS,80S	GSST-I-S-0075-080	0.71	0.72 - 0.79	0.035	0.3	4.15	2.2	3.5	1/2	1/4 Open End	1/4 MNPT	10000
1	10	GSST-I-S-0100-010	1.04	1.06 - 1.16	0.055	0.4	4.13	6.3	9.7	5/8	1/4 Open End	1/16 MNPT	10000
	40,STD,40S	GSST-I-S-0100-040	0.99	1.02 - 1.11	0.055	0.4	4.13	5.6	8.7	5/8	1/4 Open End	1/16 MNPT	10000
	80,XS,80S	GSST-I-S-0100-080	0.90	0.92 - 1.02	0.055	0.4	4.13	4.5	6.9	5/8	1/4 Open End	1/16 MNPT	10000
	160	GSST-I-S-0100-160	0.78	0.79 - 0.85	0.035	0.3	4.15	2.8	4.4	1/2	1/4 Open End	1/4 MNPT	10000
1-1/4	10	GSST-I-S-0125-010	1.38	1.39 - 1.54	0.068	1.0	5.13	15	23	3/4	3/8 Open End	1/8 MNPT	10000
	40,STD,40S	GSST-I-S-0125-040	1.31	1.33 - 1.48	0.068	0.9	5.13	13	20	3/4	3/8 Open End	1/8 MNPT	10000
	80,XS,80S	GSST-I-S-0125-080	1.21	1.23 - 1.38	0.065	0.8	5.13	11	17	3/4	3/8 Open End	1/8 MNPT	10000
	160	GSST-I-S-0125-160	1.11	1.12 - 1.22	0.055	0.5	4.13	7.2	11	5/8	1/4 Open End	1/16 MNPT	10000
1-1/2	XX	GSST-I-S-0125-XX	0.86	0.87 - 0.94	0.045	0.3	4.15	3.5	5.5	1/2	1/4 Open End	1/4 MNPT	10000
	10	GSST-I-S-0150-010	1.60	1.64 - 1.80	0.085	1.5	5.94	24	37	1	7/16 Open End	1/4 MNPT	10000
	40,STD,40S	GSST-I-S-0150-040	1.53	1.56 - 1.73	0.085	1.4	5.94	21	33	1	7/16 Open End	1/4 MNPT	10000
	80,XS,80S	GSST-I-S-0150-080	1.42	1.45 - 1.62	0.085	1.2	5.94	18	28	1	7/16 Open End	1/4 MNPT	10000
2	160	GSST-I-S-0150-160	1.27	1.30 - 1.44	0.068	0.9	5.13	12	19	3/4	3/8 Open End	1/8 MNPT	10000
	XX	GSST-I-S-0150-XX	1.05	1.08 - 1.16	0.055	0.4	4.13	6.3	9.8	5/8	1/4 Open End	1/16 MNPT	10000
	10	GSST-I-S-0200-010	2.03	2.05 - 2.28	0.130	2.9	6.94	47	75	1-1/4	9/16 Open End	3/8 MNPT	10000
	40,STD,40S	GSST-I-S-0200-040	1.94	1.97 - 2.19	0.130	2.6	6.94	42	65	1-1/4	9/16 Open End	3/8 MNPT	10000
2-1/2	80,XS,80S	GSST-I-S-0200-080	1.81	1.84 - 2.06	0.130	2.3	6.94	36	55	1-1/4	9/16 Open End	3/8 MNPT	10000
	160	GSST-I-S-0200-160	1.60	1.64 - 1.80	0.085	1.5	5.94	24	37	1	7/16 Open End	1/4 MNPT	10000
	XX	GSST-I-S-0200-XX	1.42	1.45 - 1.62	0.085	1.2	5.94	18	28	1	7/16 Open End	1/4 MNPT	10000
	10	GSST-I-S-0250-010	2.51	2.57 - 2.77	0.125	4.8	7.88	85	135	1-3/8	9/16 Open End	3/8 MNPT	8000
3	40,STD,40S	GSST-I-S-0250-040	2.34	2.38 - 2.61	0.125	4.2	7.88	75	115	1-3/8	9/16 Open End	3/8 MNPT	8000
	80,XS,80S	GSST-I-S-0250-080	2.20	2.24 - 2.46	0.125	3.8	7.88	65	100	1-3/8	9/16 Open End	3/8 MNPT	8000
	160	GSST-I-S-0250-160	2.00	2.06 - 2.25	0.125	2.8	6.94	46	70	1-1/4	9/16 Open End	3/8 MNPT	10000
	XX	GSST-I-S-0250-XX	1.69	1.74 - 1.89	0.085	1.6	5.94	27	42	1	7/16 Open End	1/4 MNPT	10000
3-1/2	10	GSST-I-S-0300-010	3.07	3.10 - 3.44	0.193	7.8	8.00	150	230	1-5/8	3/4 Box End	1/4 FNPT	8000
	40,STD,40S	GSST-I-S-0300-040	2.88	2.92 - 3.25	0.193	6.9	8.00	130	200	1-5/8	3/4 Box End	1/4 FNPT	8000
	80,XS,80S	GSST-I-S-0300-080	2.71	2.75 - 3.09	0.190	6.2	8.00	110	175	1-5/8	3/4 Box End	1/4 FNPT	8000
	160	GSST-I-S-0300-160	2.50	2.56 - 2.76	0.125	4.8	7.88	85	130	1-3/8	9/16 Open End	3/8 MNPT	8000
4	XX	GSST-I-S-0300-XX	2.18	2.24 - 2.42	0.125	3.7	6.94	55	85	1-1/4	9/16 Open End	3/8 MNPT	8000
	10	GSST-I-S-0350-010	3.56	3.61 - 3.96	0.204	11.5	8.88	225	350	1-3/4	7/8 Box End	3/8 FNPT	6000
	40,STD,40S	GSST-I-S-0350-040	3.34	3.39 - 3.75	0.204	10.4	8.88	195	305	1-3/4	7/8 Box End	3/8 FNPT	6000
	80,XS,80S	GSST-I-S-0350-080	3.16	3.21 - 3.56	0.208	9.3	8.88	175	270	1-3/4	7/8 Box End	3/8 FNPT	6000
4	XX	GSST-I-S-0350-XX	2.60	2.66 - 2.86	0.125	5.1	7.88	95	145	1-3/8	9/16 Open End	3/8 MNPT	8000
	120	GSST-I-S-0400-120	3.42	3.52 - 3.83	0.205	10.7	8.88	205	320	1-3/4	7/8 Box End	3/8 FNPT	6000
	160	GSST-I-S-0400-160	3.23	3.33 - 3.64	0.205	9.8	8.88	185	285	1-3/4	7/8 Box End	3/8 FNPT	6000
	XX	GSST-I-S-0400-XX	2.96	2.99 - 3.34	0.193	7.3	8.00	135	215	1-5/8	3/4 Box End	1/4 FNPT	8000



## 5. Preparing the GripSafe ST ORB Plug for Installation

- 5.1 Before use, add 3-4 drops of mineral oil into the hole labeled “OIL” on the **ORB Spring Plate’s(3)**, see Figure 4.

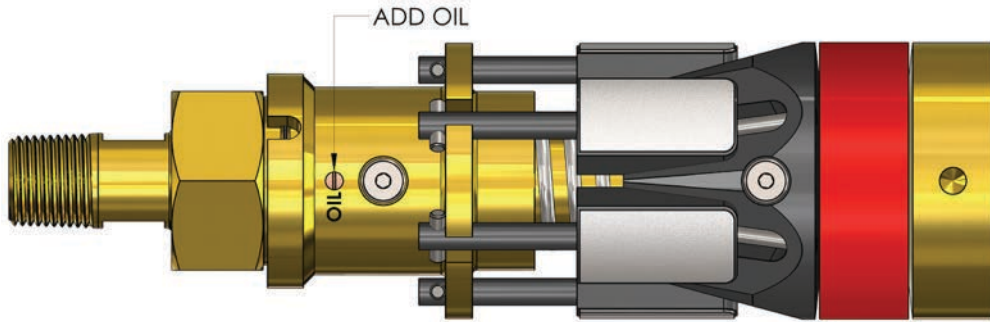

Figure 4: Adding Oil to the ORB Spring Plate’s Oil Hole

- The GripSafe ST ORB plug should be in the **Retracted** position from the factory, see Figure 5.

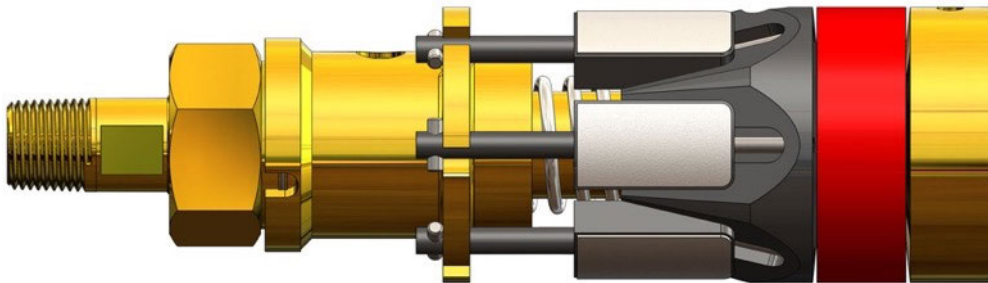

Figure 5: Not Ready to Install State (Retracted)

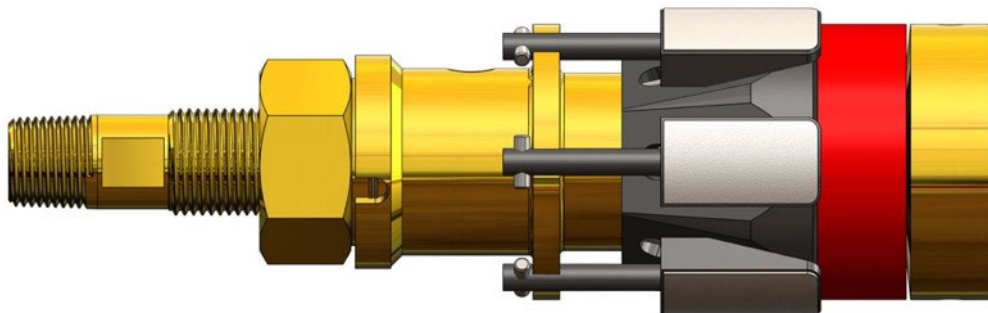

Figure 6: Ready to Install State (Compressed)

5.2 Tighten the **Compression Hex Nut(2)** so that the **ORB Spring Plate(3)** becomes flush to the **Wedge Cone(6)**, see Figure 6.

- Do not over torque the **Compression Hex Nut(2)** to the point that the **Seal(9)** starts to expand over the OD of the plug.
- In the Compressed state, shown in Figure 6, the GripSafe ST ORB plug will immediately grip the pipe upon insertion.



**CHECK:** Ensure plug is clean of debris, fouling, and contaminants before each use. Each **Wedge Gripper(11)** should slide freely up and down in its slot with a full range of motion and without resistance. **Wedge Gripper(11)** with impeded movement due to debris, dirt, contaminants or other fouling will cause the plug to not grip on the pipe's inner diameter, which can cause the plug to eject under pressure, leading to personnel injury or death, material loss, and damage to equipment.

## 6. Installing the GripSafe ST ORB Plug



**CAUTION:** Ensure pipe I.D. is clean. Debris, pipe scaling, and rust layer must be removed to the deepest point the plug will be installed into. If the pipe is lined or has irremovable product, **STOP** and contact USA Industries for support before proceeding. Failure to do so may impede the wedge's ability to grip and cause the plug to eject under pressure. Be sure to wear proper PPE and follow all site guidelines.

6.1 Insert the GripSafe ST ORB plug into the pipe.

- See Table 2 for clearance requirements and ensure the installation pipe inner diameter falls within the Internal Diameter Range.

6.2 Slowly push the plug into the pipe.

6.3 A slight rocking motion will assist installation.

- Once the **Wedge Grippers(11)** contact the inner diameter of the pipe, it will automatically grip and removal of the plug at this point is not possible, see *Section 8* for plug removal if necessary.

6.4 Push the GripSafe ST ORB plug further into the pipe to the desired depth. The top of the **ORB Spring Plate's(3)** slotted section must not be protruding past the face of the fitting or pipe it is installed in. See Figure 7 for properly installed plug and Figure 8 for improperly installed plug. The top of the **ORB Spring Plate's(3)** slotted section can be inserted further into the fitting or pipe if necessary.

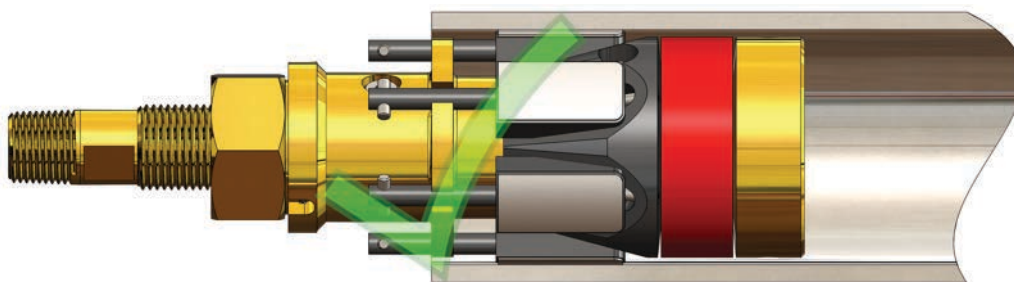

Figure 7: GripSafe ST ORB minimum insertion depth in a sectioned pipe

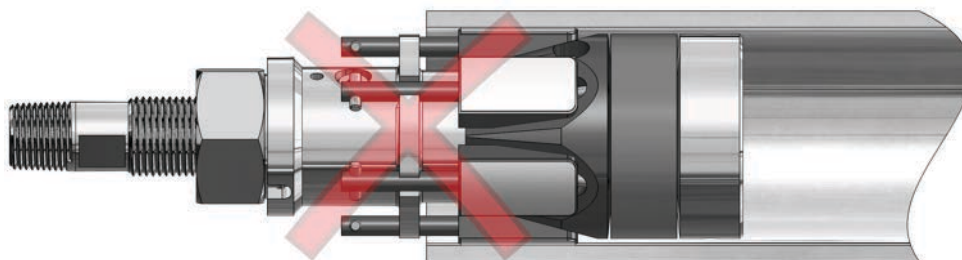

Figure 8: GripSafe ST ORB incorrect insertion depth in a sectioned pipe

- 6.5 Use a crow's foot attached to a torque wrench to torque the **Compression Hex Nut(2)** while holding the Backup Hex or flats on the **Shaft(1)** stationary with a wrench until the Minimum Compression Torque (Table 2) is reached.



**TEMPERATURE NOTE:** If welding is to occur on the pipe while the plug is installed, the **Seal(9)** should be installed a minimum of 6" from the center of an active weld to prevent it from degrading or ultimately failing due to melting. For post weld heat treats, bake-outs, etc., the **Seal(9)** should be at least 12" from the nearest edge of the heating element, and the temperature at the depth the plug is installed at should not exceed 220° F. If a high temperature bake out is being performed (400° F or higher) increase the installation depth as much as possible. It is recommended to always monitor the pressure behind the plug (ORB) and/or between the seals (DBB) and stop work immediately if any pressure drop is detected. In addition, the pipe's external surface temperature should always be monitored corresponding to the plug's seal location to ensure damage to the seal does not occur.



**CAUTION:** Using an impact wrench is not recommended as it can damage both the **Spring Plate Alignment Screw(4)** and **Wedge Cone Alignment Screw(7)** for sizes ¾" – 2" or **Spring Plate and Wedge Cone Alignment Key(20)** for sizes 2-1/2" and above.



**CAUTION:** Failure to use a backup wrench to keep the shaft stationary will place excessive stress on the **Wedge Cone Alignment Screw(7)** for sizes ¾" – 2", or **Spring Plate and Wedge Cone Alignment Key(20)** for sizes 2-1/2" and above, which could cause failure, resulting in a stuck plug and/or cause it to eject under pressure.

- 6.6 Verify integrity of the **Seal(9)**.

- If the plug is being used for pressure testing, use proper fittings to install a hydrotest pump to the **Vent Port(16)**. Otherwise, install a cap to seal off the system or a backpressure monitoring tee.
- It may be desirable to attach a gauge and vent hose assembly, backpressure monitoring tee, to the **Vent Port(16)** to bleed off any backpressure. The hose should be long enough to redirect any vapor coming out of the vessel to a safe location away from workers that may be in the area. A valve may also be attached to this port to allow safe backpressure removal during plug removal, see *Section 8*. If using a backpressure monitoring tee it may be useful to have a pressure gauge on the bull side of the tee while connecting the run side to the **Vent Port(16)** and a ball valve. Further advantages can be made by attaching



**CAUTION:** Fast flowing gases or liquids through hosing can cause hose whip. Take caution to avoid this, failure to do so may result in injury to personnel or damage to equipment.

- a hose to the ball valve on the monitoring tee and running the hose to vent to a safe location away from workers that may be in the area.
- Increase pressure to 20% of target pressure or 100 psig, whichever is less. Observe seal integrity by visually inspecting for leaks. Observance of pressure drop may not be an indication of leakage. USA Industries seals will creep under pressure until they are fully seated. This creep will increase the pressure test volume. Depending on the test volume size this may be by such a trivial amount it will not be seen on a gauge. For relatively small test volumes a noticeable gradual loss in pressure may be observed during this creep phase. Seating the seal is obtained by reapplying pressure until the pressure becomes stable. This seal creep may also be observed when the system is subjected to the full pressure. Resolution to the creep is the same at high pressure and while verifying integrity.



**CAUTION:** Do not stand directly in front of the GripSafe ST Outboard Retraction Blocking at any time. Installed plugs should always be treated in this manner irrespective if the plug has backpressure on it or not.



**CAUTION:** If backpressure develops, constant observation of pressure observed through the use of an attached gauge and physical observation of pipe integrity is necessary to ensure safety to personnel and equipment. Any bulging, enlargement or tapering of the pipe is an indication of over pressuring. The Backpressure Rating listed in Table 2 is for the pressure holding capability of the GripSafe ST Outboard Retraction Blocking and could be well beyond the system design limitations in which it is being used to test.



## 7. Removal of GripSafe ST ORB Plug

---

- 7.1 Depressurize system through the hydrotest pump or the valve on a backpressure monitoring tee and drain all water.
- 7.2 Ensure there is no backpressure on the GripSafe ST ORB plug.



**CAUTION: SLOWLY** open **Vent Port(16)** to relieve any back pressure. Care must be taken when opening valves or loosening fittings if any inadvertent backpressure was introduced to the vessel. Failure to do so may result in hazardous pressure flow and/or fittings becoming violently hazardous projectiles that may cause injury to personnel and damage to equipment. If utilizing a backpressure monitoring tee, fast flowing gases or liquids through hosing can cause hose whip. Take caution to avoid this, failure to do so may result in injury to personnel and damage to equipment.

### 7.3 Loosen the **Compression Hex Nut(2)**.

- Once the **Seal(9)** has freed itself from the pipe internal diameter, water may flow out from the pipe, be prepared to capture this if desired. Continue loosening the **Compression Hex Nut(2)** slowly until the wedges are fully relaxed (Retracted) and the seal has been freed from the pipe, see Figure 5.

### 7.4 Remove the GripSafe ST ORB plug from the pipe.

- Clean and store for later use or return to USA Industries.
- **Wedge Grippers(11)** texture may become plugged with pipe scale and rust through several uses of the plug. Inspection of this surface after each use is necessary to keep the gripping strength at peak performance. To clean, simply use mild dishwashing soap and a stiff stainless steel bristled brush such as a welding brush. If plugging is persistent, use of a household rust remover along with a stiff stainless steel bristled brush should be sufficient. Rinse plug clean of any residual chemicals with tap water and dry thoroughly.
- Inspect **Wedge Grippers'(11)** freedom of motion. Each **Wedge Gripper(11)** should slide freely up and down in its slot with a full range of motion and without resistance.
- Store out of direct sunlight in an area not exposed to above 150° F, UV light and excessive heat will cause **Seal(9)** degradation over time.

## 8. Installing and Using Safety Gag



**NOTE:** Safety Gags are not required but are recommended to provide a layer of protection in the unlikely event of plug discharge.

- 8.1 Slide the loosely assembled Safety Gag over the pipe before inserting the plug.
- 8.2 Follow the plug installation instructions in Sections 5-6 to install the GripSafe ST ORB before continuing to step 8.4.
- 8.3 Place the pear-shaped link over the **Back Pressure Vent Port(16)**.
- 8.4 Push the clamp further down the pipe to remove all slack in the chain. Ensure that the chain is not snagged, twisted, or knotted, and is tight from the gag bolt to the pear-shaped link.
- 8.5 Starting with the two bolts nearest the pipe, snug all of the bolts on the clamp. For the two bolts nearest the pipe, turn an additional 1/3-1/2 turn.
  - When properly installed, the Safety Gag should be firmly clamped and not be able to rotate, slide, or tilt in any fashion when pushed or pulled.
  - See Figure 9 for an example of a properly installed Safety Gag.
- 8.6 Reverse steps 8.1-8.5 to uninstall.

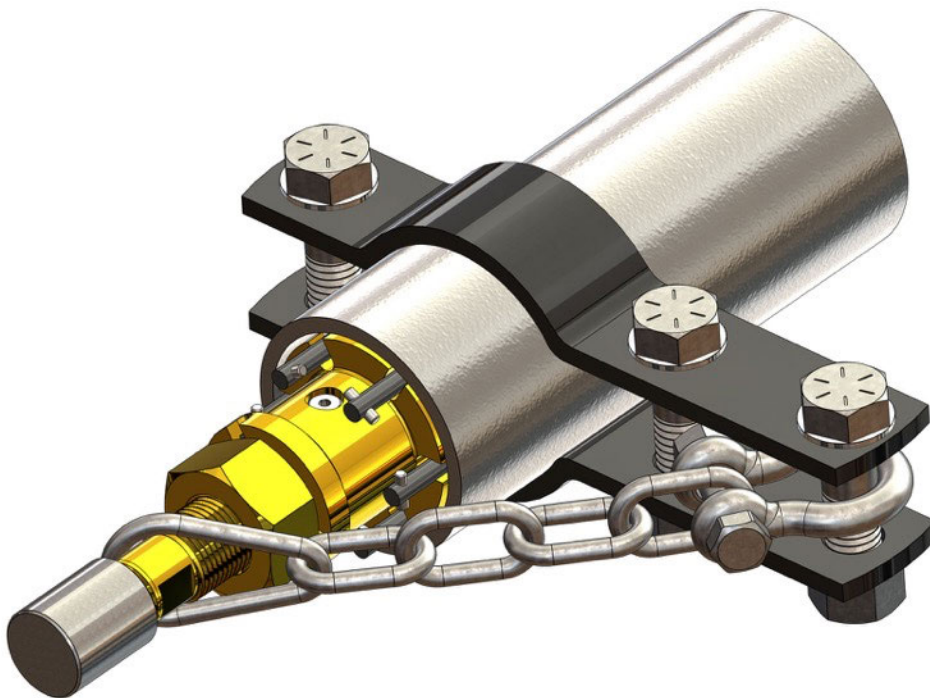

Figure 9: Properly Installed Safety Gag on Pipe

**GripSafe®ST is a registered trademark of USA Industries**

