



GRIPSAFE[®] ST

INSTALLATION MANUAL

NPS 4''* - 12''



NPS 14'' - 24''**



Large Inboard Insertion Blocking (IIB) Plug

*Schedules 120, 160 & XXH use our Small IIB Plug

**Larger sizes available upon request

Manufactured Exclusively by USA Industries, an ISO
9001:2015 Certified Company

For patent and trademark information, go to
<https://www.USAIindustries.com/gripsafe-patents/trademarks/>

www.USAIindustries.com

(713) 941-3797 • (800) 456-8721

315 State Street • S. Houston, TX 77587



Table of Contents

1. Introduction	1
2. Safety	2
3. Parts.....	3
4. Specifications	6
5. Preparing the GripSafe ST Inboard Retraction Blocking Plug for Installation	10
6. Installing the GripSafe ST Inboard Insertion Blocking.....	11
7. GripSafe ST Inboard Insertion Blocking Plug Removal.....	15
8. GripSafe ST Lifting Device	17
9. Installing the lifting device on the GripSafe ST plug.	18

1. Introduction

Thank you for choosing GripSafe ST pipe plugging technology. This manual covers the proper use of this technology to ensure safe operating conditions. All necessary sockets, wrenches and lifting device to install this equipment are available for rental/purchase from USA Industries, LLC. See **Section 4 Table 2** for sockets and **Section 8 Table 3** for lifting device.

The information in this manual is intended for the use of a GripSafe ST plug in metallic piping. If the intended use of this plug is for any piping other than metallic piping please contact USA Industries, Customer Service Department for technical support

-  Do not use GripSafe ST equipment before fully reading and comprehending and comprehending this manual
-  Failure to follow this manual in full may result in injury to personnel and damage to equipment.

2. Safety

- ⚠ Failure to follow proper safety requirements may result in the GripSafe ST Plug failing, which could lead to personnel injury, material loss, and damage to equipment.
- ⚠ Wear proper PPE when performing any task with the GripSafe ST Plug as defined by site safety rules. Always follow site procedure for safely lifting and operating equipment.
- ⚠ Never install the GripSafe® Plug in a position where the Gripping Wedges would be located over a weld droop or ridge.
- ⚠ Never install the Seals or Gripping Wedges over a section of pipe that is missing its interior wall; e.g. weldolet, tee, etc.
- ⚠ Use care in the handling of the Wedge Studs. Never beat, hammer, or pry on the Wedge Studs. Never remove the nut located on the Wedge Studs.
- ⚠ Pressure testing can be an extremely hazardous operation and safety precautions should be strictly adhered to. Never stand or pass in front of any test plug while installed or while testing is in progress.
- ⚠ Do not make any adjustment while the plug is under pressure.
- ⚠ Do not exceed rated pressure stamped on the plug. Plugs are rated for holding pressure in one direction only, never apply pressure on the non-rated side of the plug.
- ⚠ Backpressure rating on the plug is in reference to the plugs ultimate holding capacity. Never exceed the pressure capacity of the weakest component in a pressurized system. It is imperative that a system's components be studied prior to beginning a pressure test to confirm the maximum test pressure a system can be subjected to in accordance with all applicable industry and site-specific standards.
- ⚠ It is recommended that water be used as the test medium. Venting all gases from the vessel being pressurized is necessary before pressurizing the system.
- ⚠ In the event pneumatic testing is required, all attempts to limit potential damage to any personnel or equipment must be made. USA Industries recommends Nitrogen as the medium for pneumatic testing as it does not support combustion. Follow provisions outlined in ASME PCC-2 Repair of Pressure Equipment and Piping when testing pneumatically.
- ⚠ The Inboard Insertion Blocking GripSafe ST Plug is designed to hold pressure originating from the installation side only.
- ⚠ Careful observation is needed at the location of the pipe where the Wedge Grippers make contact while performing a hydro test. If any deformation or swelling of the pipe is observed, stop immediately and slowly release the pressure from the system. Contact USA Industries for further assistance.
- ⚠ If at any time during hydro-testing a popping or clicking sound is heard, stop immediately and slowly release the pressure from the system. Popping or clicking sounds during hydro-testing could be a sign of the Wedge Gripper slipping, cracking, or plug components failing. Remove the plug from the pipe or fitting and inspect for damage. Contact USA Industries for further assistance.
- ⚠ Ensure plug is clean of debris, fouling, and contaminants before each use. Each Wedge Gripper should freely slide up and down in its slots with a full range of motion and without any resistance. With impeded movement due to debris, dirt, contaminants, or other fouling will cause the plug to not grip on the pipe's inner diameter, which can cause it to eject under pressure, leading to personnel injury or death, material loss, and damage to equipment.
- ⚠ For any questions or concerns, contact USA Industries for technical assistance.

3. Parts

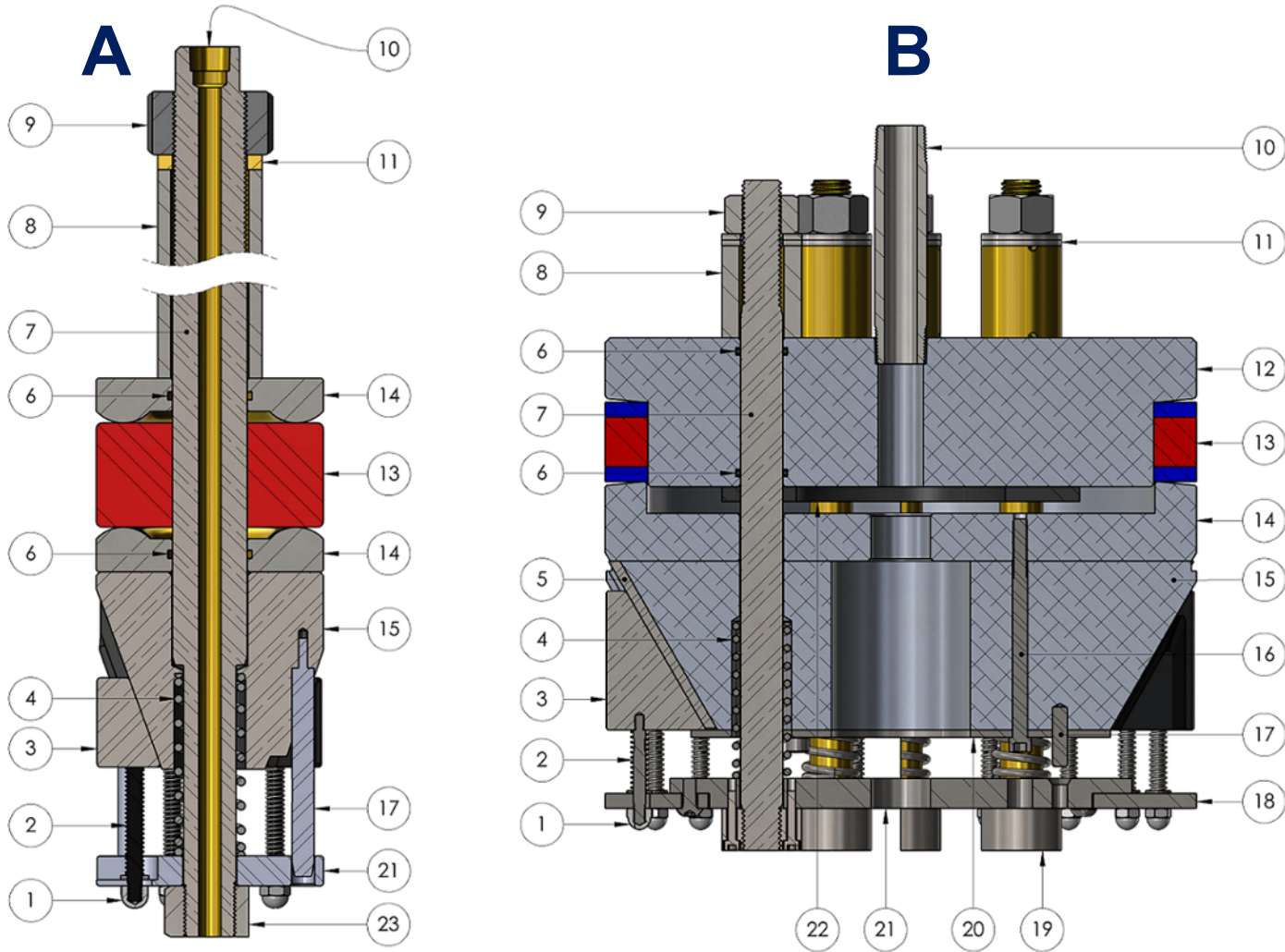

Figure 1: A- 4" | B – 6" – 24" GripSafe ST Inboard Insertion Blocking Diagram

Table 1: GripSafe ST Bill Of Materials

Nominal Pipe Size (in)	Schedule	(1) Wedge Gripper Nut	(2) Wedge Gripper Stem	(3) Wedge Gripper	(4) Retraction Compression Spring	(5) Back Plate	(6) Shaft O-Ring	(7) Threaded Shaft	(8) Compression Spacer	(9) Compression Hex Nut	(10) Vent Port	(11) Thrust Washer	(12) Bottom Compression Plate	(13) Seal	(14) Compression Plate	(15) Wedge Cone	(16) Wedge Cone Retaining Screw	(17) Alignment Dowel Pin	(18) Spring Plate Halo	(19) Threaded Puck	(20) Retainer Plate	(21) Spring Plate Hub	(22) Seal Dampener	(23) Spring Plate Retaining Nut
4	10, 10S	6	6	6	1	0	2	1	1	1	1	1	1	1	2	1	0	3	0	0	0	1	0	1
	40, STD, 40S	6	6	6	1	0	2	1	1	1	1	1	1	1	2	1	0	3	0	0	0	1	0	1
	80, XS, 80S	6	6	6	1	0	2	1	1	1	1	1	1	1	2	1	0	3	0	0	0	1	0	1
6	10, 10S	9	9	9	1	9	8	4	4	4	1	8	1	1	1	1	2	2	0	1	1	1	0	0
	40, STD, 40S	9	9	9	1	9	8	4	4	4	1	8	1	1	1	1	2	2	0	1	1	1	0	0
	80, XS, 80S	9	9	9	1	9	8	4	4	4	1	8	1	1	1	1	2	2	0	1	1	1	0	0
	120	8	8	8	1	8	8	4	4	4	1	8	1	1	1	1	2	2	0	1	1	1	0	0
	160	7	7	7	1	7	8	4	4	4	1	8	1	1	1	1	2	2	0	1	1	1	0	0
	XX	6	6	6	1	6	8	4	4	4	1	8	1	1	1	1	2	2	0	1	1	1	0	0
8	10, 10S	15	15	15	1	15	8	4	4	4	1	8	1	1	1	1	2	2	0	1	1	1	0	0
	20	15	15	15	1	15	8	4	4	4	1	8	1	1	1	1	2	2	0	1	1	1	0	0
	30	15	15	15	1	15	8	4	4	4	1	8	1	1	1	1	2	2	0	1	1	1	0	0
	40, STD, 40S	15	15	15	1	15	8	4	4	4	1	8	1	1	1	1	2	2	0	1	1	1	0	0
	60	15	15	15	1	15	8	4	4	4	1	8	1	1	1	1	2	2	0	1	1	1	0	0
	80, XS, 80S	15	15	15	1	15	8	4	4	4	1	8	1	1	1	1	2	2	0	1	1	1	0	0
	100	14	14	14	1	14	8	4	4	4	1	8	1	1	1	1	2	2	0	1	1	1	0	0
	120	13	13	13	1	13	8	4	4	4	1	8	1	1	1	1	2	2	0	1	1	1	0	0
	140	13	13	13	1	13	8	4	4	4	1	8	1	1	1	1	2	2	0	1	1	1	0	0
	160	12	12	12	1	12	8	4	4	4	1	8	1	1	1	1	2	2	0	1	1	1	0	0
XX	12	12	12	1	12	8	4	4	4	1	8	1	1	1	1	2	2	0	1	1	1	0	0	
10	10, 10S	13	13	13	4	13	8	4	4	4	1	8	1	1	1	1	2	2	1	4	1	1	0	0
	20	13	13	13	4	13	8	4	4	4	1	8	1	1	1	1	2	2	1	4	1	1	0	0
	30	13	13	13	4	13	8	4	4	4	1	8	1	1	1	1	2	2	1	4	1	1	0	0
	40, STD, 40S	13	13	13	4	13	8	4	4	4	1	8	1	1	1	1	2	2	1	4	1	1	0	0
	60, XS, 80S	12	12	12	4	12	8	4	4	4	1	8	1	1	1	1	2	2	1	4	1	1	0	0
	80	11	11	11	4	11	8	4	4	4	1	8	1	1	1	1	2	2	1	4	1	1	0	0
	100	11	11	11	1	11	8	4	4	4	1	8	1	1	1	1	2	2	1	4	1	1	0	0
	120	10	10	10	1	10	8	4	4	4	1	8	1	1	1	1	2	2	1	4	1	1	0	0
12	140, XX	9	9	9	1	9	8	4	4	4	1	8	1	1	1	1	2	2	1	4	1	1	0	0
	160	9	9	9	1	9	8	4	4	4	1	8	1	1	1	1	2	2	1	4	1	1	0	0
	10, 10S	18	18	18	6	18	12	6	6	6	1	12	1	1	1	1	4	2	1	6	1	1	1	0
	20	18	18	18	6	18	12	6	6	6	1	12	1	1	1	1	4	2	1	6	1	1	1	0
	30	17	17	17	6	17	12	6	6	6	1	12	1	1	1	1	4	2	1	6	1	1	1	0
	STD, 40S	17	17	17	6	17	12	6	6	6	1	12	1	1	1	1	4	2	1	6	1	1	1	0
	40	17	17	17	6	17	12	6	6	6	1	12	1	1	1	1	4	2	1	6	1	1	1	0
	XS, 80S	16	16	16	6	16	12	6	6	6	1	12	1	1	1	1	4	2	1	6	1	1	1	0
	60	16	16	16	6	16	12	6	6	6	1	12	1	1	1	1	4	2	1	6	1	1	1	0
	80	16	16	16	6	16	12	6	6	6	1	12	1	1	1	1	4	2	1	6	1	1	1	0
14	100	15	15	15	4	15	8	4	4	4	1	8	1	1	1	1	2	2	1	4	1	1	1	0
	120, XX	14	14	14	4	14	8	4	4	4	1	8	1	1	1	1	2	2	1	4	1	1	1	0
	140	13	13	13	4	13	8	4	4	4	1	8	1	1	1	1	2	2	1	4	1	1	1	0
	160	13	13	13	4	13	8	4	4	4	1	8	1	1	1	1	2	2	1	4	1	1	1	0
	10S	15	15	15	6	15	12	6	6	6	1	12	1	1	1	1	4	2	1	6	1	1	1	0
	10	15	15	15	6	15	12	6	6	6	1	12	1	1	1	1	4	2	1	6	1	1	1	0
	20	15	15	15	6	15	12	6	6	6	1	12	1	1	1	1	4	2	1	6	1	1	1	0
	30, STD, 40S	14	14	14	6	14	12	6	6	6	1	12	1	1	1	1	4	2	1	6	1	1	1	0
	40	14	14	14	6	14	12	6	6	6	1	12	1	1	1	1	4	2	1	6	1	1	1	0
	XS, 80S	14	14	14	6	14	12	6	6	6	1	12	1	1	1	1	4	2	1	6	1	1	1	0
60	19	19	19	6	19	12	6	6	6	1	12	1	1	1	1	4	2	1	6	1	1	1	0	
80	18	18	18	6	18	12	6	6	6	1	12	1	1	1	1	4	2	1	6	1	1	1	0	
100	17	17	17	6	17	12	6	6	6	1	12	1	1	1	1	4	2	1	6	1	1	1	0	
120	17	17	17	6	17	12	6	6	6	1	12	1	1	1	1	4	2	1	6	1	1	1	0	
140	16	16	16	6	16	12	6	6	6	1	12	1	1	1	1	4	2	1	6	1	1	1	0	
160	15	15	15	6	15	12	6	6	6	1	12	1	1	1	1	4	2	1	6	1	1	1	0	

Table 1: GripSafe ST Bill Of Materials Con't.

Nominal Pipe Size (in)	Schedule	(1) Wedge Gripper Nut	(2) Wedge Gripper Stem	(3) Wedge Gripper	(4) Retraction Compression Spring	(5) Back Plate	(6) Shaft O-Ring	(7) Threaded Shaft	(8) Compression Spacer	(9) Compression Hex Nut	(10) Vent Port	(11) Thrust Washer	(12) Bottom Compression Plate	(13) Seal	(14) Compression Plate	(15) Wedge Cone	(16) Wedge Cone Retaining Screw	(17) Alignment Dowel Pin	(18) Spring Plate Halo	(19) Threaded Puck	(20) Retainer Plate	(21) Spring Plate Hub	(22) Seal Dampener	(23) Spring Plate Retaining Nut
16	10S	19	19	19	6	19	12	6	6	6	1	12	1	1	1	4	2	1	6	1	1	1	0	
	10	19	19	19	6	19	12	6	6	6	1	12	1	1	1	4	2	1	6	1	1	1	0	
	20	19	19	19	6	19	12	6	6	6	1	12	1	1	1	4	2	1	6	1	1	1	0	
	30,STD,40S	18	18	18	6	18	12	6	6	6	1	12	1	1	1	4	2	1	6	1	1	1	0	
	40,XS,80S	18	18	18	6	18	12	6	6	6	1	12	1	1	1	4	2	1	6	1	1	1	0	
	60	17	17	17	6	17	12	6	6	6	1	12	1	1	1	4	2	1	6	1	1	1	0	
	80	22	22	22	6	22	12	6	6	6	1	12	1	1	1	4	2	1	6	1	1	1	0	
	100	21	21	21	6	21	12	6	6	6	1	12	1	1	1	4	2	1	6	1	1	1	0	
	120	21	21	21	6	21	12	6	6	6	1	12	1	1	1	4	2	1	6	1	1	1	0	
140	19	19	19	6	19	12	6	6	6	1	12	1	1	1	4	2	1	6	1	1	1	0		
160	19	19	19	6	19	12	6	6	6	1	12	1	1	1	4	2	1	6	1	1	1	0		
18	10S	18	18	18	6	18	12	6	6	6	1	12	1	1	1	4	2	1	6	1	1	1	0	
	10	18	18	18	6	18	12	6	6	6	1	12	1	1	1	4	2	1	6	1	1	1	0	
	20	18	18	18	6	18	12	6	6	6	1	12	1	1	1	4	2	1	6	1	1	1	0	
	STD,40S	17	17	17	6	17	12	6	6	6	1	12	1	1	1	4	2	1	6	1	1	1	0	
	30	17	17	17	6	17	12	6	6	6	1	12	1	1	1	4	2	1	6	1	1	1	0	
	XS,80S	17	17	17	6	17	12	6	6	6	1	12	1	1	1	4	2	1	6	1	1	1	0	
	40	21	21	21	6	21	12	6	6	6	1	12	1	1	1	4	2	1	6	1	1	1	0	
	60	21	21	21	6	21	12	6	6	6	1	12	1	1	1	4	2	1	6	1	1	1	0	
	80	20	20	20	6	20	12	6	6	6	1	12	1	1	1	4	2	1	6	1	1	1	0	
	100	26	26	26	6	26	12	6	6	6	1	12	1	1	1	4	2	1	6	1	1	1	0	
120	25	25	25	6	25	12	6	6	6	1	12	1	1	1	4	2	1	6	1	1	1	0		
140	24	24	24	6	24	12	6	6	6	1	12	1	1	1	4	2	1	6	1	1	1	0		
160	23	23	23	6	23	12	6	6	6	1	12	1	1	1	4	2	1	6	1	1	1	0		
20	10S	20	20	20	8	20	16	8	8	8	1	16	1	1	1	6	2	1	8	1	1	1	0	
	10	20	20	20	8	20	16	8	8	8	1	16	1	1	1	6	2	1	8	1	1	1	0	
	20,STD,40S	20	20	20	8	20	16	8	8	8	1	16	1	1	1	6	2	1	8	1	1	1	0	
	30,XS,80S	20	20	20	8	20	16	8	8	8	1	16	1	1	1	6	2	1	8	1	1	1	0	
	40	20	20	20	8	20	16	8	8	8	1	16	1	1	1	6	2	1	8	1	1	1	0	
	60	19	19	19	8	19	16	8	8	8	1	16	1	1	1	6	2	1	8	1	1	1	0	
	80	24	24	24	8	24	16	8	8	8	1	16	1	1	1	6	2	1	8	1	1	1	0	
	100	23	23	23	8	23	16	8	8	8	1	16	1	1	1	6	2	1	8	1	1	1	0	
	120	22	22	22	8	22	16	8	8	8	1	16	1	1	1	6	2	1	8	1	1	1	0	
140	21	21	21	6	21	12	6	6	6	1	12	1	1	1	4	2	1	6	1	1	1	0		
160	20	20	20	6	20	12	6	6	6	1	12	1	1	1	4	2	1	6	1	1	1	0		
24	10,10S	23	23	23	8	23	16	8	8	8	1	16	1	1	1	6	2	1	8	1	1	1	0	
	20,STD,40S	22	22	22	8	22	16	8	8	8	1	16	1	1	1	6	2	1	8	1	1	1	0	
	XS,80S	22	22	22	8	22	16	8	8	8	1	16	1	1	1	6	2	1	8	1	1	1	0	
	30	22	22	22	8	22	16	8	8	8	1	16	1	1	1	6	2	1	8	1	1	1	0	
	40	21	21	21	8	21	16	8	8	8	1	16	1	1	1	6	2	1	8	1	1	1	0	
	60	21	21	21	8	21	16	8	8	8	1	16	1	1	1	6	2	1	8	1	1	1	0	
	80	25	25	25	8	25	16	8	8	8	1	16	1	1	1	6	2	1	8	1	1	1	0	
	100	24	24	24	8	24	16	8	8	8	1	16	1	1	1	6	2	1	8	1	1	1	0	
	120	23	23	23	8	23	16	8	8	8	1	16	1	1	1	6	2	1	8	1	1	1	0	
140	21	21	21	8	21	16	8	8	8	1	16	1	1	1	6	2	1	8	1	1	1	0		
160	20	20	20	8	20	16	8	8	8	1	16	1	1	1	6	2	1	8	1	1	1	0		

4. Specifications

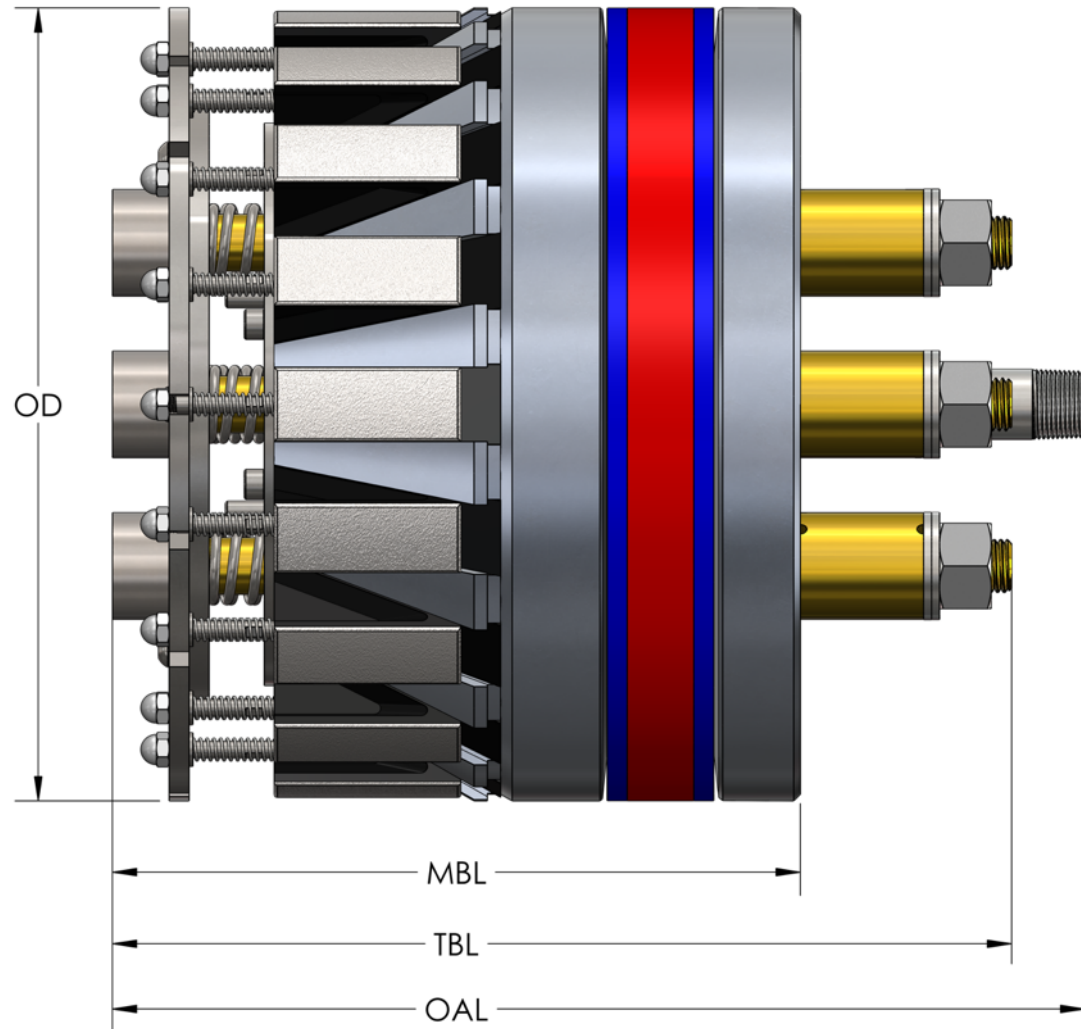

Figure 2: GripSafe ST Inboard Insertion Blocking Dimensions

Table 2: GripSafe ST Inboard Insertion Blocking Specifications

Nominal Pipe Size (in)	Schedule	Part Number	Tool Diameter (in)	Rec. ID Range* (in)	Nominal Pipe ID Clearance (in)	Approx. Tool Weight (lbs)	Tool Length (in)	Torque Range (ft-lbs)		Compression Hex Nut Socket Size (in)	Back Pressure Vent Thread	Test Pressure Rating (PSI)*	MBL Main Body Length (in)	TBL Tool Body Length w/o Nipple (in)	
								Norm	Max.						
4	10,10S	GS-I-R-0400-010	4.04	4.10 - 4.54	0.22	21	20.44	120	250	1-5/16	1/4 FNPT	4875	9.38	20.44	
	40,STD,40S	GS-I-R-0400-040	3.81	3.87 - 4.31	0.22	19	20.44	120	250	1-5/16	1/4 FNPT	5450	9.38	20.44	
	80,XS,80S	GS-I-R-0400-080	3.61	3.67 - 4.11	0.22	17	20.44	120	250	1-5/16	1/4 FNPT	6050	9.38	20.44	
6	10,10S	GS-I-R-0600-010	5.98	6.04 - 6.42	0.375	34	16.42	85	130	1-1/16	1/4 MNPT	850	10.91	14.40	
	40,STD,40S	GS-I-R-0600-040	5.69	5.75 - 6.13	0.375	32	16.42	75	110	1-1/16	1/4 MNPT	2370	10.91	14.40	
	80,XS,80S	GS-I-R-0600-080	5.39	5.45 - 5.82	0.375	29	16.42	60	95	1-1/16	1/4 MNPT	4000	10.91	14.40	
	120	GS-I-R-0600-120	5.13	5.19 - 5.56	0.375	27	16.42	55	80	1-1/16	1/4 MNPT	3900	11.30	14.40	
	160	GS-I-R-0600-160	4.81	4.87 - 5.25	0.375	25	16.42	40	60	3/4	1/4 MNPT	3850	11.05	14.13	
	XX	GS-I-R-0600-XXH	4.52	4.58 - 4.96	0.375	23	16.42	35	55	3/4	1/4 MNPT	3700	11.05	14.13	
8	10,10S	GS-I-R-0800-010	7.95	8.02 - 8.40	0.375	61	16.28	120	150	1-1/4	1/2 MNPT	575	10.88	14.40	
	20	GS-I-R-0800-020	7.75	7.81 - 8.20	0.375	59	16.28	120	150	1-1/4	1/2 MNPT	1125	10.88	14.40	
	30	GS-I-R-0800-030	7.70	7.76 - 8.15	0.375	58	16.28	120	150	1-1/4	1/2 MNPT	1300	10.88	14.40	
	40,STD,40S	GS-I-R-0800-040	7.61	7.67 - 8.05	0.375	56	16.28	120	150	1-1/4	1/2 MNPT	1575	10.88	14.40	
	60	GS-I-R-0800-060	7.44	7.50 - 7.89	0.375	55	16.28	120	150	1-1/4	1/2 MNPT	2175	10.88	14.40	
	80,XS,80S	GS-I-R-0800-080	7.25	7.31 - 7.70	0.375	53	16.28	120	150	1-1/4	1/2 MNPT	3250	10.88	14.40	
	100	GS-I-R-0800-100	7.06	7.12 - 7.51	0.375	50	16.28	100	150	1-1/4	1/2 MNPT	3860	10.91	14.40	
	120	GS-I-R-0800-120	6.81	6.87 - 7.26	0.375	48	16.28	100	150	1-1/4	1/2 MNPT	3725	10.91	14.40	
	140	GS-I-R-0800-140	6.63	6.69 - 7.07	0.375	46	16.28	90	150	1-1/16	1/4 MNPT	3925	10.91	14.40	
	160	GS-I-R-0800-160	6.44	6.50 - 6.88	0.375	44	16.28	90	150	1-1/16	1/4 MNPT	3825	10.91	14.40	
	XX	GS-I-R-0800-XXH	6.50	6.56 - 6.94	0.375	44	16.28	90	150	1-1/16	1/4 MNPT	3750	10.91	14.40	
	10	10,10S	GSST-I-R-1000-010	10.05	10.11 - 10.85	0.375	75	16.02	120	270	1-1/4	3/4 MNPT	4200	11.63	15.63
		20	GSST-I-R-1000-020	9.88	9.94 - 10.68	0.375	72	16.02	120	270	1-1/4	3/4 MNPT	4500	11.63	15.63
		30	GSST-I-R-1000-030	9.76	9.82 - 10.56	0.375	71	16.02	120	270	1-1/4	3/4 MNPT	4800	11.63	15.63
40,4STD,40s		GSST-I-R-1000-040	9.65	9.71 - 10.45	0.375	69	16.02	120	270	1-1/4	3/4 MNPT	5000	11.63	15.63	
60,XS,80S		GSST-I-R-1000-08S	9.38	9.44 - 10.18	0.375	66	16.02	120	270	1-1/4	3/4 MNPT	5975	11.63	15.63	
80		GSST-I-R-1000-080	9.19	9.25 - 9.99	0.375	63	16.02	120	200	1-1/4	3/4 MNPT	5700	11.63	15.63	
100		GSST-I-R-1000-100	8.94	9.00 - 9.74	0.375	58	16.02	120	195	1-1/4	3/8 MNPT	6000	11.63	15.63	
120		GSST-I-R-1000-120	8.69	8.75 - 9.49	0.375	56	16.02	120	185	1-1/4	3/8 MNPT	5775	11.63	15.63	
140,XX		GSST-I-R-1000-140	8.38	8.44 - 9.18	0.375	54	16.02	120	180	1-1/4	3/8 MNPT	5575	11.63	15.63	
160		GSST-I-R-1000-160	8.13	8.19 - 8.93	0.375	53	16.02	120	175	1-1/4	3/8 MNPT	5925	11.63	15.63	
12	10,10S	GSST-I-R-1200-010	12.02	12.08 - 12.82	0.375	140	16.02	120	180	1-1/4	3/4 MNPT	5500	11.63	15.63	
	20	GSST-I-R-1200-020	11.88	11.94 - 12.68	0.375	137	16.02	120	175	1-1/4	3/4 MNPT	5625	11.63	15.63	
	30	GSST-I-R-1200-030	11.72	11.78 - 12.52	0.375	133	16.02	120	175	1-1/4	3/4 MNPT	5475	11.63	15.63	
	STD,40S	GSST-I-R-1200-04S	11.63	11.69 - 12.43	0.375	131	16.02	120	250	1-1/4	3/4 MNPT	4550	11.63	15.63	
	40	GSST-I-R-1200-040	11.56	11.63 - 12.36	0.375	129	16.02	120	245	1-1/4	3/4 MNPT	4700	11.63	15.63	
	XS,80S	GSST-I-R-1200-08S	11.38	11.44 - 12.18	0.375	126	16.02	120	225	1-1/4	3/4 MNPT	5175	11.63	15.63	
	60	GSST-I-R-1200-060	11.25	11.31 - 12.05	0.375	97	16.02	120	165	1-1/4	3/4 MNPT	5575	11.63	15.63	
	80	GSST-I-R-1200-080	11.00	11.06 - 11.80	0.375	93	16.02	120	160	1-1/4	3/4 MNPT	5825	11.63	15.63	
	100	GSST-I-R-1200-100	10.69	10.75 - 11.49	0.375	89	16.02	120	235	1-1/4	3/4 MNPT	5775	11.63	15.63	
	120,XX	GSST-I-R-1200-120	10.38	10.44 - 11.18	0.375	87	16.02	120	230	1-1/4	3/4 MNPT	5700	11.63	15.63	
	140	GSST-I-R-1200-140	10.13	10.19 - 10.93	0.375	85	16.02	120	220	1-1/4	3/4 MNPT	5550	11.63	15.63	
	160	GSST-I-R-1200-160	9.75	9.81 - 10.55	0.375	81	16.02	120	215	1-1/4	3/4 MNPT	5975	11.63	15.63	

NOTE: For 6" – 8" plug sizes, OD must be within 0.125-inche concentricity to the pipe ID.

NOTE: For 10" plug sizes and above, no more than 0.500-inch clearance between the spring plate and the pipe's inner diameter is permissible for reliably safe operation of the plug.

- NEVER EXCEED THE MAXIMUM RATED PRESSURE OF THE LOWEST RATED COMPONENT IN THE SYSTEM.
- DATA IS SUBJECT TO CHANGE. For the most current version of this document, go to: <https://www.USAIndustries.com/downloads-library>, and then scroll to the GripSafe ST Operating Manual downloads.



Table 2: GripSafe ST Inboard Insertion Blocking Specifications Con't.

Nominal Pipe Size (in)	Schedule	Part Number	Tool Diameter (in)	Rec. ID Range* (in)	Nominal Pipe ID Clearance (in)	Approx. Tool Weight (lbs)	Tool Length (in)	Torque Range (ft.-lbs)		Compression Hex Nut Socket Size (in)	Back Pressure Vent Thread	Test Pressure Rating (PSI)*	MBL Main Body Length (in)	TBL Tool Body Length w/o Nipple (in)
								Norm	Max.					
14	10S	GSST-I-R-1400-01S	13.25	13.31 - 14.05	0.375	182	17.75	120	200	1-1/4	1 MNPT	6250	12.60	15.63
	10	GSST-I-R-1400-010	13.13	13.19 - 13.93	0.375	179	17.75	120	195	1-1/4	1 MNPT	6350	12.60	15.63
	20	GSST-I-R-1400-020	13.00	13.06 - 13.80	0.375	176	17.75	120	195	1-1/4	1 MNPT	6475	12.60	15.63
	30,STD,40S	GSST-I-R-1400-04S	12.88	12.94 - 13.68	0.375	170	17.75	120	205	1-1/4	1 MNPT	6175	12.60	15.63
	40	GSST-I-R-1400-040	12.75	12.81 - 13.55	0.375	169	17.75	120	195	1-1/4	1 MNPT	6275	12.60	15.63
	XS,80S	GSST-I-R-1400-08S	12.63	12.69 - 13.43	0.375	166	17.75	120	180	1-1/4	1 MNPT	6400	12.60	15.63
	60	GSST-I-R-1400-060	12.44	12.50 - 13.24	0.375	148	16.02	120	185	1-1/4	3/4 MNPT	5425	11.63	15.63
	80	GSST-I-R-1400-080	12.13	12.19 - 12.93	0.375	142	16.02	120	180	1-1/4	3/4 MNPT	5400	11.63	15.63
	100	GSST-I-R-1400-100	11.75	11.81 - 12.55	0.375	134	16.02	120	175	1-1/4	3/4 MNPT	5425	11.63	15.63
	120	GSST-I-R-1400-120	11.44	11.50 - 12.24	0.375	130	16.02	120	170	1-1/4	3/4 MNPT	5725	11.63	15.63
16	140	GSST-I-R-1400-140	11.13	11.19 - 11.93	0.375	124	16.02	120	165	1-1/4	3/4 MNPT	5700	11.63	15.63
	160	GSST-I-R-1400-160	10.81	10.88 - 11.61	0.375	118	16.02	120	160	1-1/4	3/4 MNPT	5650	11.63	15.63
	10S	GSST-I-R-1600-01S	15.25	15.31 - 16.05	0.375	252	18.06	120	310	1-5/8	1 MNPT	6000	12.90	16.88
	10	GSST-I-R-1600-010	15.13	15.19 - 15.93	0.375	249	18.06	120	305	1-5/8	1 MNPT	6100	12.90	16.88
	20	GSST-I-R-1600-020	15.00	15.06 - 15.80	0.375	246	18.06	120	300	1-5/8	1 MNPT	6200	12.90	16.88
	30,STD,40S	GSST-I-R-1600-04S	14.88	14.94 - 15.68	0.375	240	18.07	120	320	1-5/8	1 MNPT	5700	12.90	16.88
	40,XS,80S	GSST-I-R-1600-08S	14.63	14.69 - 15.43	0.375	234	18.07	120	280	1-5/8	1 MNPT	6175	12.90	16.88
	60	GSST-I-R-1600-060	14.31	14.38 - 15.11	0.375	225	18.07	120	285	1-5/8	1 MNPT	6075	12.90	16.88
	80	GSST-I-R-1600-080	13.94	14.00 - 14.74	0.375	190	16.33	120	270	1-5/8	3/4 MNPT	4975	11.90	16.88
	100	GSST-I-R-1600-100	13.56	13.63 - 14.36	0.375	191	16.33	120	270	1-5/8	3/4 MNPT	5050	11.90	16.88
18	120	GSST-I-R-1600-120	13.19	13.25 - 13.99	0.375	183	16.33	120	265	1-5/8	3/4 MNPT	5350	11.90	16.88
	140	GSST-I-R-1600-140	12.75	12.81 - 13.55	0.375	154	16.02	120	190	1-1/4	3/4 MNPT	5175	11.63	15.63
	160	GSST-I-R-1600-160	12.44	12.50 - 13.24	0.375	150	16.02	120	185	1-1/4	3/4 MNPT	5425	11.63	15.63
	10S	GSST-I-R-1800-01S	17.25	17.31 - 18.05	0.375	351	19.08	120	430	1-5/8	1 MNPT	4175	13.90	18.88
	10	GSST-I-R-1800-010	17.13	17.19 - 17.93	0.375	347	19.08	120	430	1-5/8	1 MNPT	4200	13.90	18.88
	20	GSST-I-R-1800-020	17.00	17.06 - 17.80	0.375	344	19.08	120	425	1-5/8	1 MNPT	4250	13.90	18.88
	STD,40S	GSST-I-R-1800-04S	16.88	16.94 - 17.68	0.375	335	19.33	120	485	1-5/8	1 MNPT	3550	13.90	18.88
	30	GSST-I-R-1800-030	16.75	16.81 - 17.55	0.375	331	19.33	120	465	1-5/8	1 MNPT	3750	13.90	18.88
	XS,80S	GSST-I-R-1800-08S	16.63	16.69 - 17.43	0.375	328	19.33	120	440	1-5/8	1 MNPT	4000	13.90	18.88
	40	GSST-I-R-1800-040	16.50	16.56 - 17.30	0.375	288	18.07	120	410	1-5/8	1 MNPT	4350	12.90	16.88
60	GSST-I-R-1800-060	16.13	16.19 - 16.93	0.375	267	18.07	120	400	1-5/8	1 MNPT	4450	12.90	16.88	
80	GSST-I-R-1800-080	15.75	15.81 - 16.55	0.375	266	18.07	120	390	1-5/8	1 MNPT	4525	12.90	16.88	
100	GSST-I-R-1800-100	15.31	15.38 - 16.11	0.375	234	17.10	120	380	1-5/8	1 MNPT	4650	11.90	16.88	
120	GSST-I-R-1800-120	14.88	14.94 - 15.68	0.375	215	17.22	120	370	1-5/8	1 MNPT	4900	11.90	16.88	
140	GSST-I-R-1800-140	14.50	14.56 - 15.30	0.375	211	17.35	120	360	1-5/8	1 MNPT	5075	11.90	16.88	
160	GSST-I-R-1800-160	14.06	14.13 - 14.86	0.375	201	17.47	120	345	1-5/8	1 MNPT	5150	11.90	16.88	

NOTE: For 6" – 8" plug sizes, OD must be within 0.125-inch concentricity to the pipe ID.

NOTE: For 10" plug sizes and above, no more than 0.500-inch clearance between the spring plate and the pipe's inner diameter is permissible for reliably safe operation of the plug.

• NEVER EXCEED THE MAXIMUM RATED PRESSURE OF THE LOWEST RATED COMPONENT IN THE SYSTEM.

• DATA IS SUBJECT TO CHANGE. For the most current version of this document, go to: <https://www.USAIndustries.com/downloads-library>, and then scroll to the GripSafe ST Operating Manual downloads.

Table 2: GripSafe® ST Inboard Insertion Blocking Specifications Con't.

Nominal Pipe Size (in)	Schedule	Part Number	Tool Diameter (in)	Rec. ID Range* (in)	Nominal Pip ID Clearance (in)	Approx. Tool Weight (lbs)	Tool Length (in)	Torque Range (ft-lbs)		Compression Hex Nut Socket Size (in)	Back Pressure Vent Thread	Test Pressure Rating (PSI)*	MBL Main Body Length (in)	TBL Tool Body Length w/o Nipple (in)
								Norm	Max.					
20	10S	GSST-I-R-2000-01S	19.19	19.25 - 19.99	0.375	438	19.56	120	365	1-5/8	1-1/2 MNPT	5000	14.17	18.88
	10	GSST-I-R-2000-010	19.13	19.19 - 19.93	0.375	436	19.56	120	360	1-5/8	1-1/2 MNPT	5025	14.17	18.88
	20,STD,40S	GSST-I-R-2000-04S	18.88	18.94 - 19.68	0.375	427	19.56	120	415	1-5/8	1-1/2 MNPT	4275	14.17	18.88
	30,XS,80S	GSST-I-R-2000-08S	18.63	18.69 - 19.43	0.375	415	19.56	120	375	1-5/8	1-1/2 MNPT	4500	14.17	18.88
	40	GSST-I-R-2000-040	18.44	18.50 - 19.24	0.375	409	19.56	120	350	1-5/8	1-1/2 MNPT	5250	14.17	18.88
	60	GSST-I-R-2000-060	18.00	18.06 - 18.80	0.375	391	19.56	120	340	1-5/8	1-1/2 MNPT	5375	14.17	18.88
	80	GSST-I-R-2000-080	17.56	17.63 - 18.36	0.375	336	18.30	120	330	1-5/8	1-1/2 MNPT	5475	13.16	16.88
	100	GSST-I-R-2000-100	17.06	17.13 - 17.86	0.375	320	18.30	120	320	1-5/8	1-1/2 MNPT	5625	13.16	16.88
	120	GSST-I-R-2000-120	16.63	16.69 - 17.43	0.375	305	18.30	120	310	1-5/8	1-1/2 MNPT	5750	13.16	16.88
	140	GSST-I-R-2000-140	16.13	16.19 - 16.93	0.375	279	18.42	120	400	1-5/8	1-1/2 MNPT	5950	13.28	16.88
24	160	GSST-I-R-2000-160	15.69	15.75 - 16.49	0.375	265	18.42	120	390	1-5/8	1-1/2 MNPT	5975	13.28	16.88
	10,10S	GSST-I-R-2400-01S	23.13	23.19 - 23.93	0.375	653	20.36	120	465	1-5/8	1-1/2 MNPT	3700	15.17	18.88
	20,STD,40S	GSST-I-R-2400-04S	22.88	22.94 - 23.68	0.375	635	20.36	120	510	1-5/8	1-1/2 MNPT	3600	15.17	18.88
	XS,80S	GSST-I-R-2400-08S	22.63	22.69 - 23.43	0.375	625	20.36	120	465	1-5/8	1-1/2 MNPT	3675	15.17	18.88
	30	GSST-I-R-2400-030	22.50	22.56 - 23.30	0.375	626	20.36	120	450	1-5/8	1-1/2 MNPT	3725	15.17	18.88
	40	GSST-I-R-2400-040	22.25	22.31 - 23.05	0.375	608	20.36	120	445	1-5/8	1-1/2 MNPT	3650	15.17	18.88
	60	GSST-I-R-2400-060	21.69	21.75 - 22.49	0.375	585	20.36	120	435	1-5/8	1-1/2 MNPT	3825	15.17	18.88
	80	GSST-I-R-2400-080	21.19	21.25 - 21.99	0.375	518	19.56	120	425	1-5/8	1-1/2 MNPT	4375	14.17	18.88
	100	GSST-I-R-2400-100	20.56	20.63 - 21.36	0.375	492	19.56	120	410	1-5/8	1-1/2 MNPT	4500	14.17	18.88
	120	GSST-I-R-2400-120	20.00	20.06 - 20.80	0.375	468	19.69	120	395	1-5/8	1-1/2 MNPT	5250	14.30	18.88
140	GSST-I-R-2400-140	19.50	19.56 - 20.30	0.375	450	19.81	120	385	1-5/8	1-1/2 MNPT	5100	14.42	18.88	
160	GSST-I-R-2400-160	18.94	19.00 - 19.74	0.375	428	19.94	120	375	1-5/8	1-1/2 MNPT	5125	14.55	18.88	

NOTE: For 6" – 8" plug sizes, OD must be within 0.125-inch concentricity to the pipe ID.

NOTE: For 10" plug sizes and above, no more than 0.500-inch clearance between the spring plate and the pipe's inner diameter is permissible for reliably safe operation of the plug.

• NEVER EXCEED THE MAXIMUM RATED PRESSURE OF THE LOWEST RATED COMPONENT IN THE SYSTEM.

• DATA IS SUBJECT TO CHANGE. For the most current version of this document, go to: <https://www.USAIndustries.com/downloads-library>, and then scroll to the GripSafe ST Operating Manual downloads.

5. Preparing the GripSafe ST IIB Plug for Installation

- The GripSafe ST Inboard Retraction Blocking should be in the “Ready to Install” position from the factory.

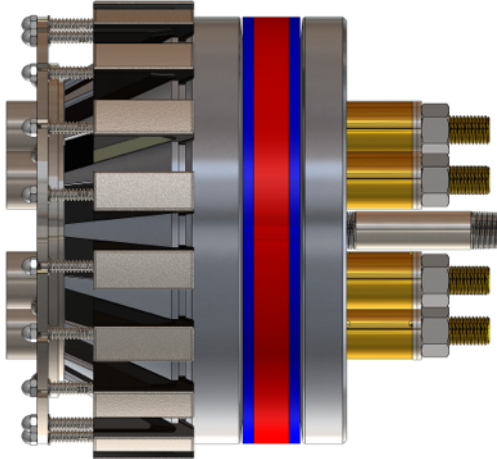

Figure 3: Not Ready to Install
(Compressed)

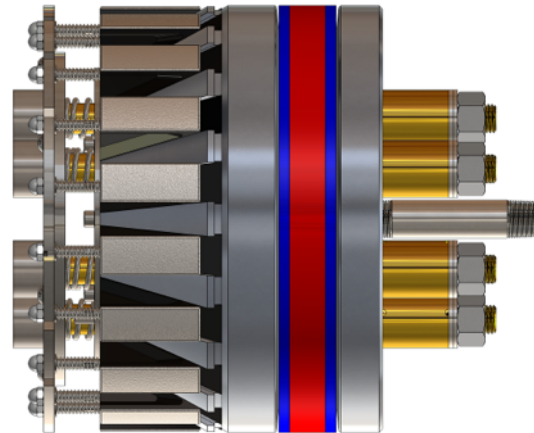

Figure 4: Ready to Install
(Retracted)

- Ensure the **Compression Hex Nuts(9)**, are not tightened and the **Spring Plate Hub(21)**, is in the Retracted state as seen in *Figure 4*.
- In the Compressed state, shown in *Figure 3*, the GripSafe ST Plug’s **Wedge Grippers(3)** will obstruct insertion into the pipe.
- In the Retracted state, shown in *Figure 4*, the GripSafe ST Plug will not immediately grip the pipe upon insertion.
- If the plug is being used for pressure testing, install a cap on **Vent Port(10)**, to seal the system.



CHECK: Ensure plug is clean of debris, fouling, and contaminants before each use. Each **Wedge Gripper(3)** should slide freely up and down in its slot with a full range of motion and without resistance. **Wedge Gripper(3)** with impeded movement due to debris, dirt, contaminants or other fouling will cause the plug to not grip on the pipe’s inner diameter, which can cause the plug to eject under pressure, leading to personnel injury or death, material loss, and damage to equipment.



NOTE: To check IIB **Wedge Gripper’s(3)** freedom of movement, the **Compression Hex Nuts(9)** have to be tightened first to the point where the **Spring Plate Hub(21)** is in the Compressed state, see *Figure 3*, and is flushed with the **Retainer Plate(20)**. After checking for **Wedge Gripper’s(3)** freedom of movement, loosen the **Compression Hex Nuts(9)** so that the plug is in the Retracted State before installation.

6. Installing the GripSafe ST IIB Plug



CAUTION: Ensure pipe I.D. is clean. Debris, pipe scaling, and rust layer must be removed to the deepest point the plug will be installed into. If the pipe is lined or has irremovable product, **STOP** and contact USA Industries for support before proceeding. Failure to do so may impede the wedge's ability to grip and cause the plug to eject under pressure. Be sure to wear proper PPE and follow all site guidelines.

- 6.1. Insert the GripSafe ST Inboard Insertion Blocking Plug evenly into the pipe.
 - See **Table 2** for Operational ID Range and clearance.
 - For using GripSafe ST Lifting Device, see **Section 8**.
- 6.2. When inserting the GripSafe ST Plug into the pipe, insert **Spring Plate Hub(21)** side first, see *Figure 5*.
 - When testing a weld neck flange weld, the **Bottom Compression Plates(12)**, must be inserted past the weld droop and the end of the **Vent Port(10)**, must be at least 1" away from the face of the weld neck flange, see *Figure 5*.

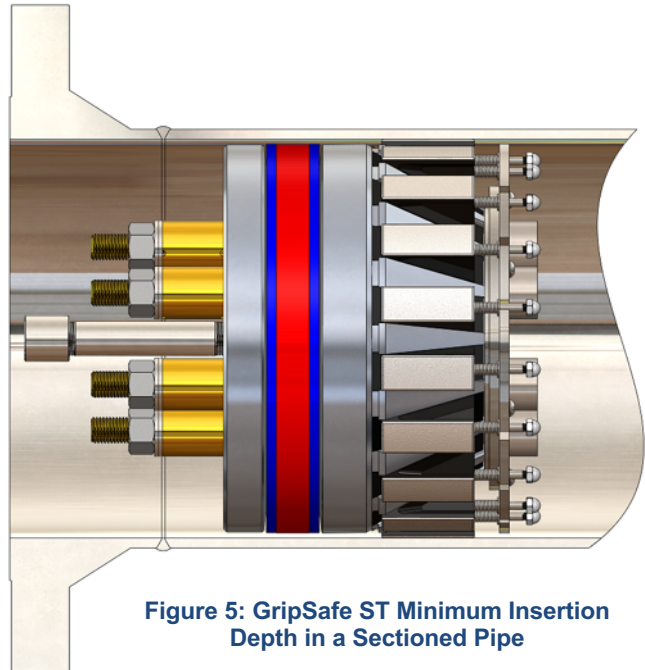

Figure 5: GripSafe ST Minimum Insertion Depth in a Sectioned Pipe



CAUTION: GripSafe ST IIB is designed to hold pressure originating from the installation side only. If pressure is anticipated on the other side of the plug, contact USA Industries for possible solution, see Figure 9. Disregarding this caution may result in the GripSafe ST Plug ejecting, which could lead to personnel injury, material loss, and damage.



CAUTION: In the Retracted state, it is important to note the plug will not be immediately gripping the pipe upon insertion. Only after tightening the **Compression Hex Nut(9)**, while plug is in the pipe, to advance the bottom of the **Spring Plate Hub(21)** to contact the **Retainer Plate(20)**, will the plug be securely gripping the pipe.



TEMPERATURE NOTE: If welding is to occur on the pipe while the plug is installed, the **Seal (Tri-Ply™)(8)** should be installed a minimum of 6" from the center of an active weld to prevent it from degrading or ultimately failing due to melting. For post weld heat treats, bake-outs, etc., the **Seal (Tri-Ply™)(8)** should be at least 12" from the nearest edge of the heating element, and the temperature at the depth the plug is installed at should not exceed 220° F. If a high temperature bake out is being performed (400° F or higher) increase the installation depth as much as possible.

6.3. When the plug is in the desired depth, check the plug to pipe alignment.

- For NPS 6" - 8" plugs, use the .350" portion of the GripSafe No-Go Gauge. If the .350" portion of the No-Go Gauge goes in between the plug's outer diameter and the pipe's inner diameter, repositioning the plug is required, see Figure 6 "REPOSITIONING REQUIRED". If the .350" portion of the No-Go Gauge does not go in between the plug's outer diameter and the pipe's inner diameter as shown in Figure 6 "NO REPOSITIONING REQUIRED" proceed to the next step.
- For NPS 10" plugs and above, use the .500" portion of the GripSafe No-Go Gauge. If the .500" portion of the No-Go Gauge goes in between the plug's outer diameter and the pipe's inner diameter, repositioning the plug is required, see Figure 7 "REPOSITIONING REQUIRED". If the .500" portion of the No-Go Gauge does not go in between the plug's outer diameter and the pipe's inner diameter as shown in Figure 7 "NO REPOSITIONING REQUIRED" proceed to the next step.

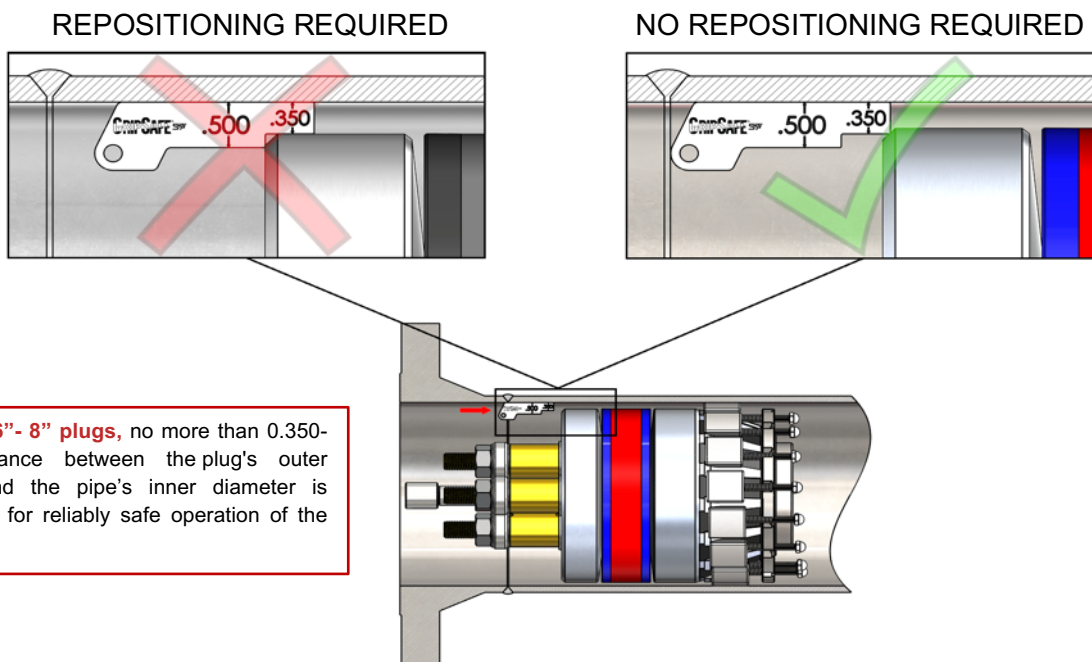

For sizes 6" - 8" plugs, no more than 0.350-inch clearance between the plug's outer diameter and the pipe's inner diameter is permissible for reliably safe operation of the plug.

Figure 6: Sizes 6" – 8" GripSafe ST Plug and Pipe Concentricity

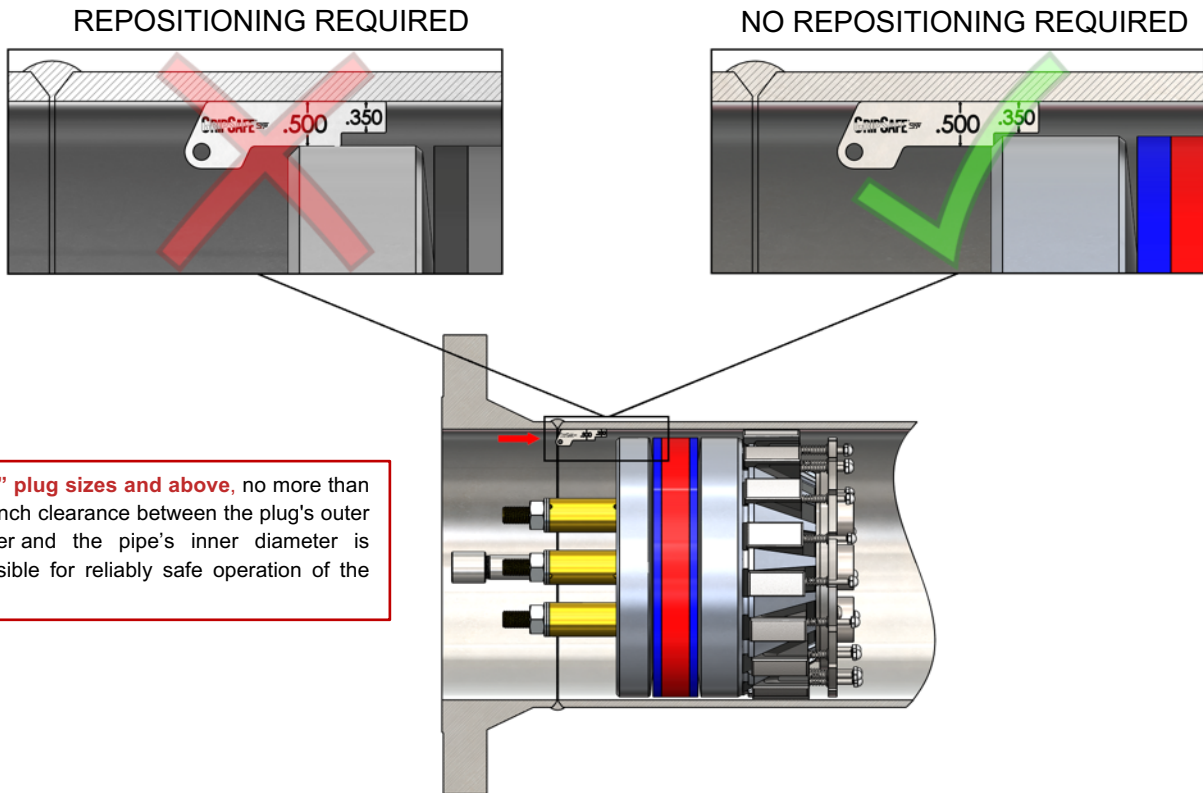

Figure 7: Sizes 10" and above GripSafe ST Plug and Pipe Concentricity

6.4. Evenly tighten the Compression Nuts.

- Using a star pattern shown in *Figure 7*, turn each **Compression Hex Nut(9)** 3 full revolutions before moving to the next. Repeat until 50% target torque is achieved on all nuts then increase to 100% target installation torque. After completing the star pattern at 100% of target torque, use a circular pattern to confirm all nuts are torqued correctly.
- Minimal torque will be required for the first several passes, however the torque will increase notably after the **Seal(13)** begins to compress against the pipe inner diameter.

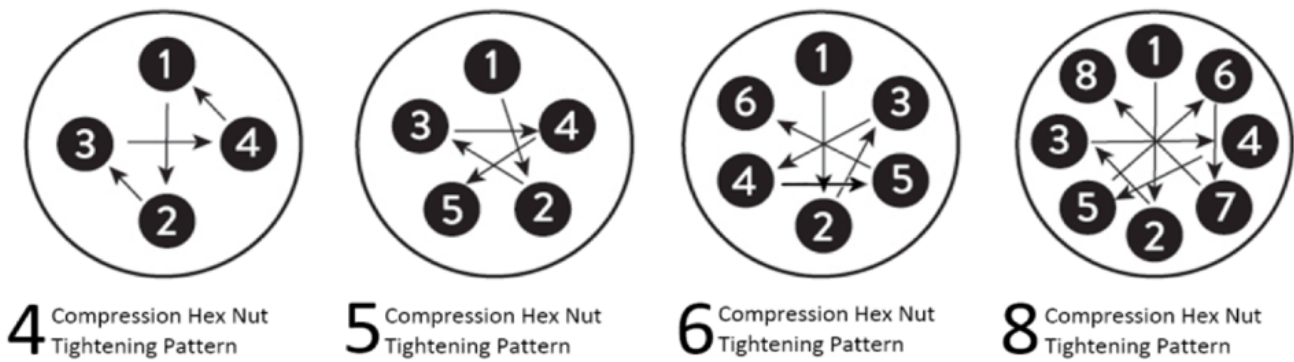

Figure 8: Compression Hex Nut Tightening Pattern Examples

6.5. Install Gasket and IIB Blind Flange

- Use in house procedures to install the appropriate gasket and IIB blind flange for the application.
- Follow gasket manufacturer's torque and installation procedure or use an approved in-house procedure.

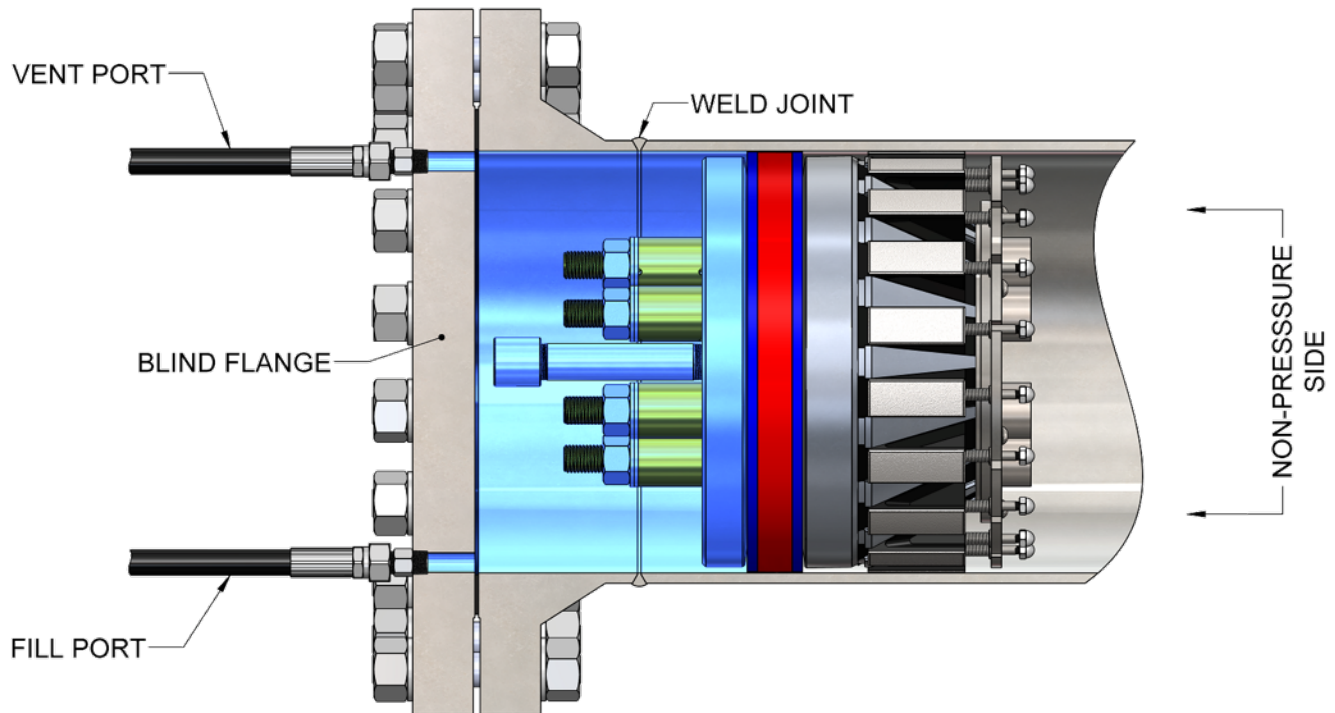

Figure 9: GripSafe Weld Neck Flange Hydrotesting

- 6.6. Attach the hydro pump's hose to the NPT Fill Port of the Blind Flange.
- 6.7. Bleed off air by pumping water into the system while keeping the Vent Port Open, see Figure 8.
- 6.8. Once air has been purged, plug or attach a hose to the NPT Vent Port.
- 6.9. Pressurize system through the Flange ports and verify the integrity of the Seals.
 - Increase pressure to 25% of target pressure or 150 psig, whichever is less. Observance of pressure drop may not be an indication of leakage. USA Industries **Seals(13)** will creep under pressure until they are fully seated. This creep will increase the pressure test volume. Depending on the test volume size this may be by such a trivial amount it will not be seen on a gauge. For relatively small test volumes a noticeable gradual loss in pressure may be observed during this creep phase. Seating the seal is obtained by reapplying pressure until the pressure becomes stable. This seal creep may also be observed when the system is subjected to the full pressure. Resolution to the creep is the same at high pressure and while verifying integrity.

7. GripSafe ST Inboard Insertion Blocking Plug Removal

- 7.1. Depressurize system using the pressure bleed-off valve on the hydro test pump equipment.
- 7.2. Remove the hydro pump's hose from the NPT Fill Port to bleed water out of the system.
- 7.3. Use in house procedures to remove the gasket and IIB blind flange from the system.



CAUTION: SLOWLY open **Vent Port(10)** to relieve any pressure build up at the back of the plug.

- 7.4. Loosen the **Compression Hex Nuts(9)** in an even star pattern as to not place the whole load on one bolt.
 - If a **Compression Hex Nut(9)**, runs free during loosening, run the nut back so the **Compression Spacer(8)** is touching the face of the **Bottom Compression Plates(12)**. The **Seal(13)** acts as a spring containing a large amount of force too great for one **Threaded Shaft(7)**, to handle.
 - After the **Seal(13)** has fully decompressed, the torque required will be notably less.
 - Once the **Seal(13)** has broken free from the pipe ID, continue loosening the **Compression Hex Nut(9)** until they are even with the top of the **Threaded Shaft(7)**.



NOTE: Do not remove the **Compression Hex Nuts(19)** from the bolt. If this happens, immediately reinstall the components.



CAUTION: Ensure that all **Compression Hex Nut(9)** maintain a load on them during the entire loosening process. Having all **Compression Hex Nut(9)** loose but one means that large load may be left on one **Threaded Shaft(7)** and the risk of breakage is probable. Once the seals have relaxed enough to break the seal from the pipe inner diameter the plug is now in a much more relaxed state and **Compression Hex Nut(9)** can be loosened in full.

- 7.5. Remove the GripSafe ST Plug from the pipe.
 - Clean and store for later use or return to USA Industries.
 - **Wedge Grippers(3)** texture may become plugged with pipe scale and rust through several uses of the plug. Inspection of this surface after each use is necessary to keep the gripping strength at peak performance. To clean, simply use mild dishwashing soap and a stiff stainless steel bristled brush such as a welding brush. If plugging is persistent, use of a household rust remover along with a stiff stainless steel bristled brush should be sufficient. Rinse plug clean of any residual chemicals with tap water and dry thoroughly.

- Inspect **Wedge Grippers'(3)** freedom of motion. Each **Wedge Gripper(3)** should slide freely up and down in its slot with a full range of motion and without resistance.
- Store out of direct sunlight in an area not exposed to above 150° F, UV light and excessive heat will cause **Seal(13)** degradation over time.
- When replacing **Seal(13)**, make sure to inspect the **Seal Dampener(22)** for cracks, excessive permanent deformation, and/or loss of elasticity.
- If damage to the **Seal Dampener(22)** is observed as mentioned above, replace the component before using the plug for another test.

8. GripSafe ST Lifting Device

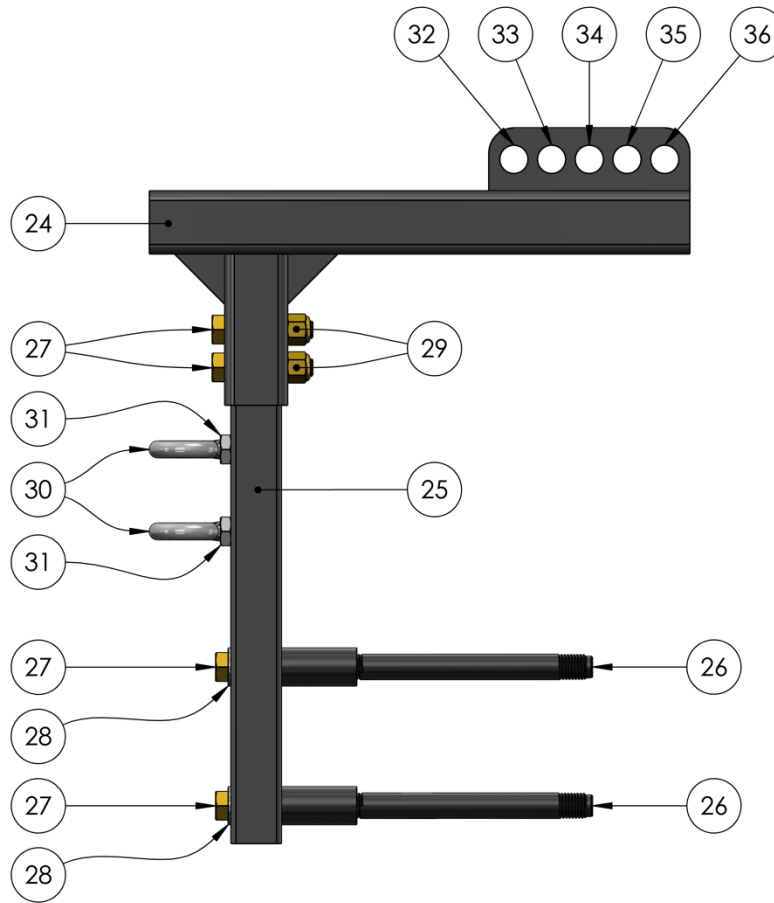

Figure 10: GripSafe ST Lifting Device Diagram

Table 3: Lifting Device Bill of Materials

Plug Size	Part Number	(24)	(25)	(25)	(26)	(26)	(26)	(26)	(27)	(28)	(29)	(30)	(31)
		Universal Lifting Bar	Telescoping Lifting Attachment #1	Telescoping Lifting Attachment #2	Lifting Standoff #1	Lifting Standoff #2	Lifting Standoff #3	Lifting Standoff #4	Lifting Device Bolt	Lifting Device Washer	Lifting Device Nut	Vertical Lifting Eyebolt	Eyebolt Nut
10	GSST-I-A-1000-ALL-LD	1	1	N/A	2	N/A	N/A	N/A	4	2	2	2	2
12	GSST-I-A-1200-ALL-LD	1	1	N/A	N/A	2	N/A	N/A	4	2	2	2	2
14	GSST-I-A-1200-ALL-LD	1	1	N/A	N/A	2	N/A	N/A	4	2	2	2	2
16	GSST-I-A-1200-ALL-LD	1	1	N/A	N/A	2	N/A	N/A	4	2	2	2	2
18	GSST-I-S-1800-ALL-LD	1	1	N/A	N/A	N/A	2	N/A	4	2	2	2	2
20	GSST-I-S-2000-ALL-LD	1	N/A	1	N/A	N/A	2	N/A	4	2	2	2	2
24	GSST-I-S-2400-ALL-LD	1	N/A	1	N/A	N/A	2	N/A	4	2	2	2	2

9. Installing the lifting device on the GripSafe ST plug.

- 9.1 Insert the **Lifting Standoffs(26)**, into the two holes located on the face of the **Bottom Compression Plates(12)**. Hand tight both **Lifting Standoffs(26)** until they bottom out, see Figure 11.



CAUTION: A minimum of 6 full turns is needed when threading both the **Lifting Standoffs(22)** into the GripSafe ST plug. Failure to ensure the studs are fully threaded-in may cause the mating threads to fail under the load of the GripSafe ST causing it to fall and potentially injuring personnel and damaging equipment.



NOTE: There are four types of **Lifting Standoffs(26)**, #1, #2, #3, and #4. #1 is used for NPS 10" both ORB and IIB plugs, and #2 is used for plugs NPS 12"-16" both ORB and IIB plugs, #3 is used for NPS 18"-24" ORB plugs only, and #4 is used for NPS 18" - 24" IIB plugs only.

- 9.2 Line up the holes on the **Telescoping Lifting Attachment(25)**, with the internally threaded holes on the **Lifting Standoffs(26)**. Fasten the **Telescoping Lifting Attachment(25)** on to the **Lifting Standoffs(26)** with the provided **Lifting Device Bolts(27)** and **Washers(28)**. See Figure 12.



NOTE: There are 2 types of **Telescoping Lifting Attachment(25)**, #1, and #2. Each differs in length and hole locations to accommodate different-sized plugs.

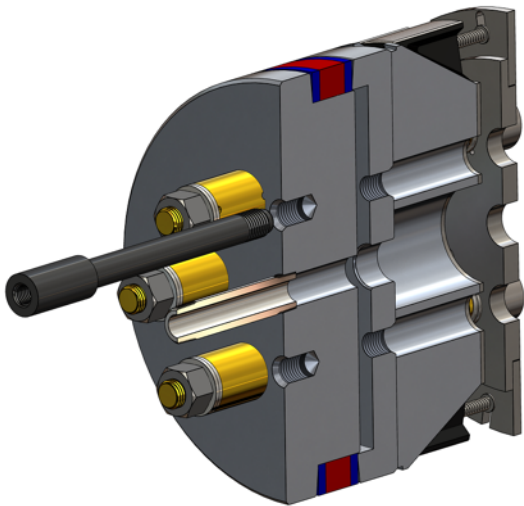

Figure 11: Inserting and Threading Lifting Standoffs into the Plug

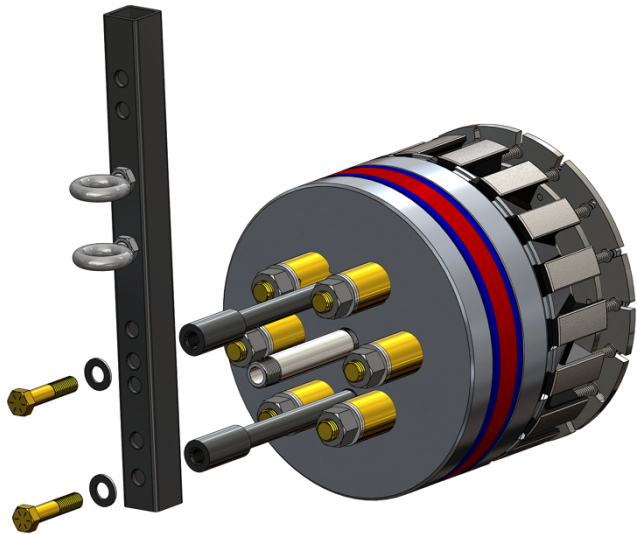

Figure 12: Aligning and fastening Telescoping Lifting Attachment on to Lifting Standoffs

- 9.3 After fastening the **Telescoping Lifting Attachment(25)** to the **Lifting Standoffs(26)**, slide it in to the **Universal Lifting Bar(24)** shorter square tubing. Upon insertion, align the two holes on both the **Telescoping Lifting Attachment(25)** and **Universal Lifting Bar(24)**. See *Figure 13*.
- 9.4 Fasten the **Telescoping Lifting Attachment(25)** with the provided **Lifting Device Bolts(27)** and **Nuts(29)**. See *Figure 13*.

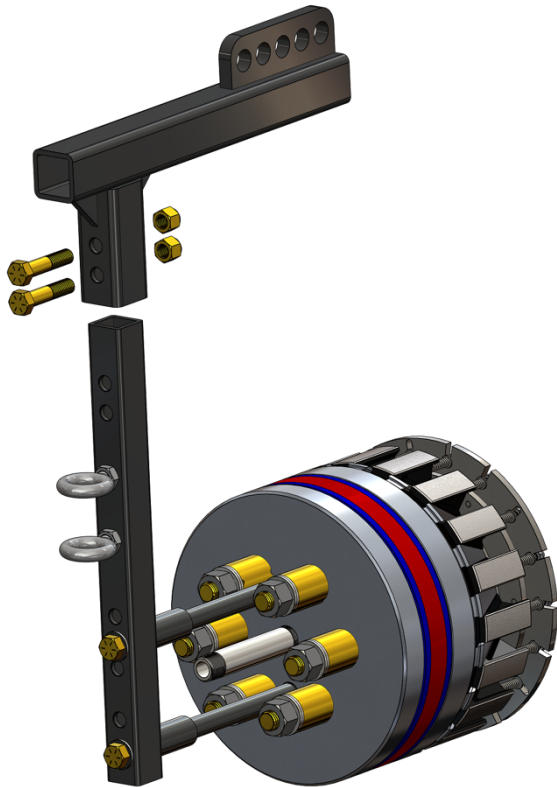

Figure 13: Aligning and Fastening Telescoping Lifting Attachment onto Universal Lifting Bar

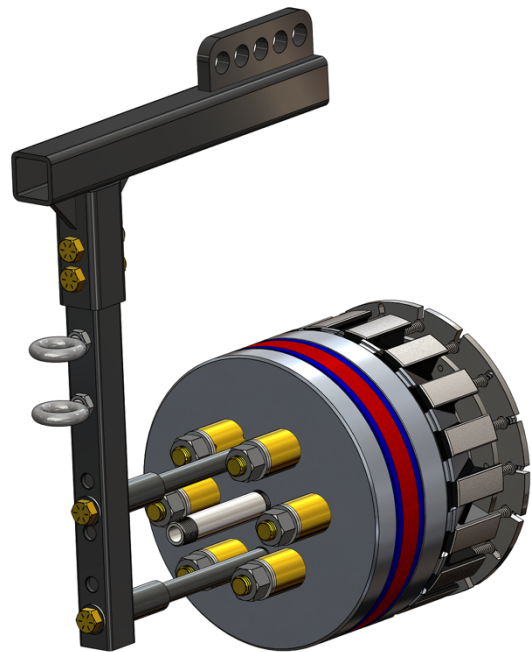

Figure 14: Lifting Device Finished Assembly

9.5 Using Lifting Device.

- There are five lifting points **(32)**, **(33)**, **(34)**, **(35)**, and **(36)** on the Lifting Device. Use one or two of the five lifting points to orient the GripSafe ST Plug horizontally.
- If the plug does not hang balanced with the center gravity, a cheater bar may be inserted in the long square tubing portion of the **Universal Lifting Bar's(24)** and used as leverage. A cheater bar can also be used to help manipulate the plug while inserting it into the pipe.



CAUTION: DO NOT lift the Lifting Device from the **Vertical Lifting Eyebolt(30) and Eyebolt Nut(31)** installed in the **Telescoping Lifting Attachment(25)**. The **Vertical Lifting Eyebolt(30) and Eyebolt Nut(31)** are threaded into the **Telescoping Lifting Attachment(25)** for storage only. Lifting from this point may cause failure and loss of control over the load resulting in damage to equipment and personnel.

9.6 Vertical Lifting

- For vertical lifting, remove the **Lifting Device Bolts(27)** that are holding the **Lifting Standoffs(26)** to the **Telescoping Lifting Attachment(25)**.
- Fasten the provided **Vertical Lifting Eyebolt(30)** and **Eyebolt Nut(31)** to both **Lifting Standoffs(26)**. Note, the **Vertical Lifting Eyebolts'(30)** thread is $\frac{3}{4}$ -10.
- While holding the **Vertical Lifting Eyebolt(30)** and **Eyebolt Nut(31)** in the correct orientation, snug its nut against the top of the **Lifting Standoffs(26)** and turn the nut an additional $\frac{1}{2}$ turn. Do the same to the other **Vertical Lifting Eyebolt(30)** and **Eyebolt Nut(31)**. See Figure 15 for properly installed **Vertical Lifting Eyebolt(30)** and **Eyebolt Nut(31)** illustration.
- When lifting vertically, both **Vertical Lifting Eyebolt(30)** and **Eyebolt Nut(31)** must be used.



CAUTION: A minimum of 6 full turns is needed when threading both eyebolt into the **Lifting Standoffs(22)**. Failure to ensure the **Vertical Lifting Eyebolts(30)** and **Eyebolt Nuts(31)** are fully threaded-in may cause the mating threads to fail under the load of the GripSafe ST causing it to fall and potentially injuring personnel and damaging equipment.



CAUTION: Lifting the GripSafe ST with only one **Vertical Lifting Eyebolt(30)** and **Eyebolt Nut(31)** is not recommended. Failing to lift the plug with both **Vertical Lifting Eyebolts(30)** and **Eyebolt Nuts(31)** could cause the plug to twist and turn which could lead to the **Vertical Lifting Eyebolts(30)** and **Eyebolt Nuts(31)** unthreading/loosening causing it to fall and potentially injuring personnel and damaging equipment.



Figure 15: Properly Installed Lifting Eyes for Vertical Lifting



GripSafe® ST is a registered trademark of USA Industries.

